

GV3

TECHNICAL GUIDE

This guide interacts with the HepcoMotion website and GV3 catalogue



Additional information can be viewed within the online GV3 catalogue when you click this icon:



To assist browsing this guide online, clicking wherever you see blue hypertext, page number, or a product icon in the page margins, will take you directly to the section required:

Cap Seals



Cap Seals
XX-XX

Where other HepcoMotion product ranges are referred to, clicking on the title will take you to the catalogue in question:

HDS2 Heavy Duty
Linear Guide

The full contents of the GV3 catalogue can be viewed or downloaded by clicking this icon:



GV3 linear guidance and transmission system

Smooth – Fast – Accurate – Quiet
Durable – Simple – Versatile – Economic

An unrivalled linear motion system, designed to serve a diverse range of automation and linear applications.

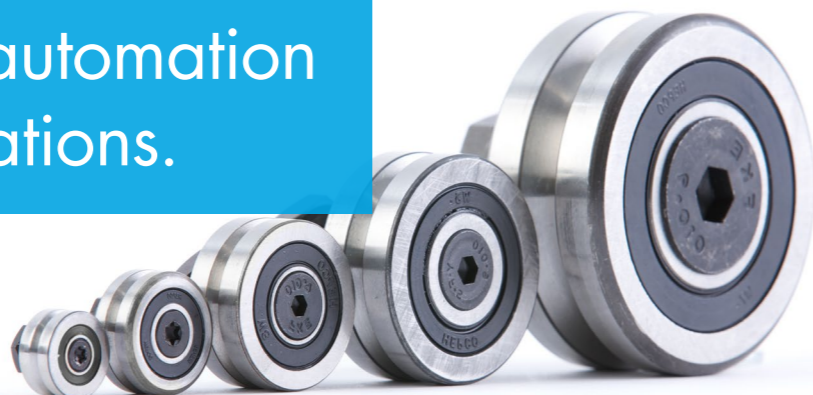

Contents

Refer also to Quick Reference icons in page margins

System Assembly & Adjustment	2 - 3	Drive System Recommendations	4 - 5
Gearboxes, Drive Flanges & AC Geared Motors	6 - 7	Drive Calculations for Rack Driven Carriages	8 - 9
Load/Life Calculation Examples	10 - 11	Deflection of Self-Supporting Slides	12
'Mix & Match' Component Compatibility	13	Data & Dimensions for Assembled Systems	14 - 19
Component Mass	20 - 23		
Removable Carriages	24 - 25	Rack & Pinion Systems	26
Shaft Pinion	27	Custom Rack Driven Carriages	28 - 29
Belt Driven Carriages	30 - 31	End Stops & Shock Absorbers	32 - 33
Carriage Locking Device	34	Flange Clamps	35
Axial Stiffness Bearing	36	Controlled Height Bearings	38
Floating Bearings	39	Vacuum & Extreme Temperature	40 - 42
Bearing & Track/Roller Lubricators	43	Bleed Lubrication	44 - 47
Side Access Adjustment	48	GV3-MCS Connectivity	50 - 53
Moment Load Carriages	Go to datasheet		

For an introduction to the GV3 product range, and examples of how the various products detailed in this Technical Guide can be used, please refer to the System Composition and Application Examples sections within the main **GV3 catalogue**.

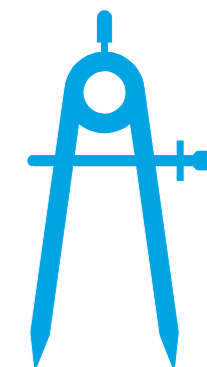

Please refer to the [Video](#) section of the HepcoMotion website for a selection of How-To videos that complement the information provided in this section of the GV3 Technical Guide.

Through Fixing Type Bearings & Track Rollers

Having loosely assembled the components (minus load), the Concentric type Bearings should be fully tightened and the Eccentric type Bearings tightened just sufficiently to permit adjustment.

The Hepco Adjusting Wrench should then be engaged with hexagon flanges of the Eccentric type Bearings and gradually turned until the Slide (or Track) is captivated between each pair of Bearings such that there is no apparent play, but with minimal pre-load.

Each pair of Bearings should then be checked for correct pre-load by rotating one of them between forefinger and thumb with the Slide (or Track) stationary so that the Bearing skids against it. A degree of resistance should be felt, but the Bearing should turn without difficulty.

When all Eccentric type Bearings have been adjusted and tested in this manner, the fixing nuts should be fully tightened to the recommended torque settings as in the table on [3](#), then checked again for pre-load as before.

Please note that too much pre-load will shorten the life of the system.

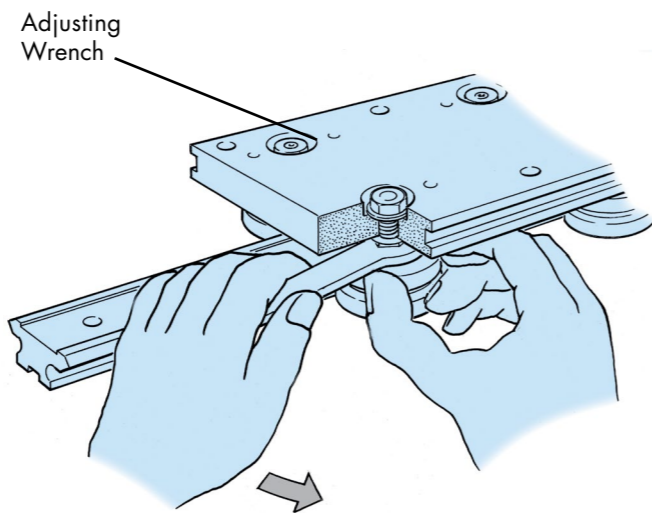

Alternative means of adjustment

Eccentric type Bearings may also be adjusted using a standard hex key and Hepco Socket Tool. This method permits re-adjustment without first having to remove Cap Seals or Cap Wipers; however, extreme care should be taken not to induce excessive pre-load, which can only be judged in this case, from the resulting friction of the system. Due to the reduced control associated with this method, it is only recommended when the Adjusting Wrench method is not possible.

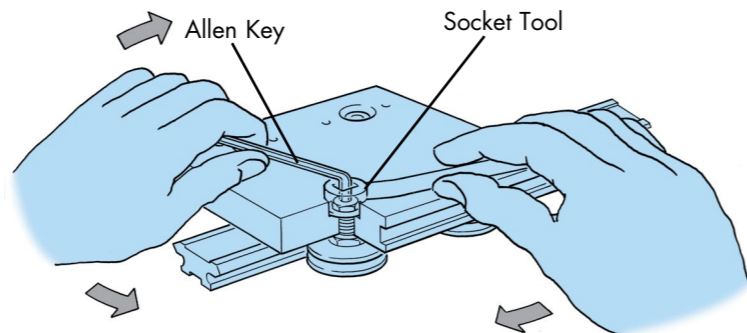

Blind Hole Fixing Type Bearings & Track Rollers

Concentric type Blind Hole Fixing Bearings (or Concentric type Blind Hole Track Rollers) are simply screwed into tapped holes in the mounting surface and tightened down using the Hepco Adjusting Wrench.

Each Eccentric type Bearing (or Track Roller) should be located by means of the two screws provided and tightened just sufficiently to still enable adjustment via the eccentric hexagon bush. The same basic procedures, as outlined for the Through Fixing type, should be used to ensure that the correct level of pre-load is applied before finally tightening down the fixing screws.

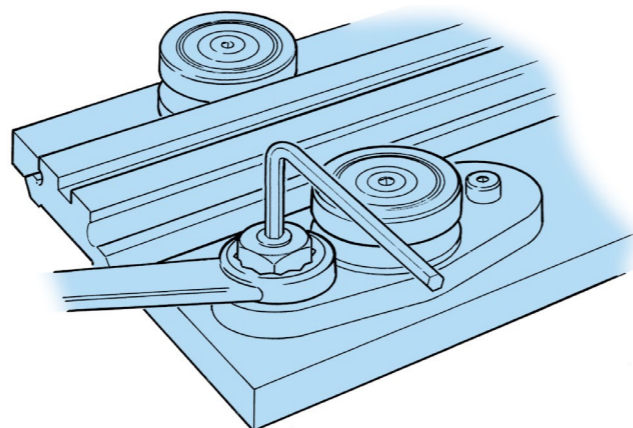

Cap Seals

Fitting of Cap Seals should be carried out after Bearing adjustment has been completed.

To fit the Cap Seals over the Bearings, the Standard Carriage should be removed from the Slide, then the Cap Seals loosely assembled to the Carriage Plate utilising either the Through Hole Fixing facility, which is the default method for Hepco Carriages, or the Tapped Hole Fixing facility, which requires tapped holes to be provided in the Carriage Plate. Two sets of plastic inserts are included with each Cap Seal to cater for both methods.

The Slide should be re-engaged with the Carriage and each Cap Seal adjusted in, until the felt wipers just make contact with the Slide 'V' surface until smearing of the lubricant is observed when the system is operated. When adjusting the Cap Seal using the Through Hole Fixing method, care should be taken to hold the plastic inserts to prevent them from moving whilst the screws are tightened.

Greater sealing effect, at the expense of increased friction, may be achieved by adjusting each Cap Seal body in further until its 'V' profile makes contact with the 'V' profile of the Slide.

The fixing screws should be fully tightened and each Cap Seal charged with a No. 2 Lithium soap-based grease until grease is seen to overflow.

Male grease connector, part No. HF 4034 or complete gun is available from Hepco, if required.

Through hole fixing

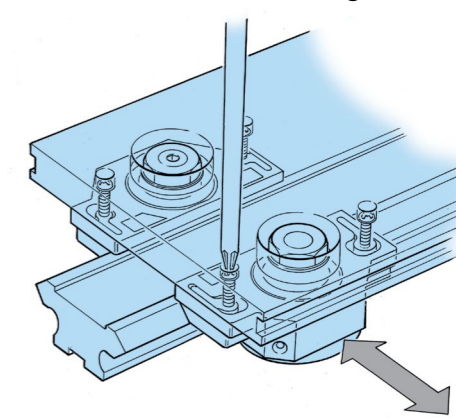

Tapped hole fixing

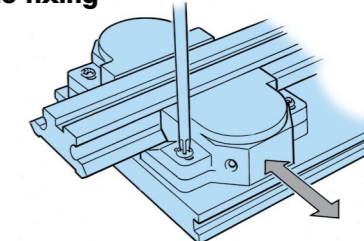

Cap Wipers

Fitting of the Cap Wipers should be carried out after Bearing adjustment has been completed.

To fit the cap wipers over the Bearings, the Slimline Carriage should be removed from the Slide, then the Cap Wipers loosely assembled to the Carriage Plate utilising either the Tapped Hole Fixing facility which is the default method for Hepco Slimline Carriages, or the Through Hole Fixing facility, which requires slotted clearance holes to be provided in the Carriage Plate for adjustment.

The Slide should then be re-engaged with the Carriage and each Cap Wiper adjusted in, until the felt wipers just make contact with the Slide 'V' surface and a smearing of the lubricant is observed when the system is operated.

The fixing screws should be fully tightened and each Cap Wiper charged with a No. 2 Lithium soap-based grease until grease is seen to overflow.

Male grease connector, part No. HF 4034 or complete gun is available from Hepco, if required.

Tapped hole fixing

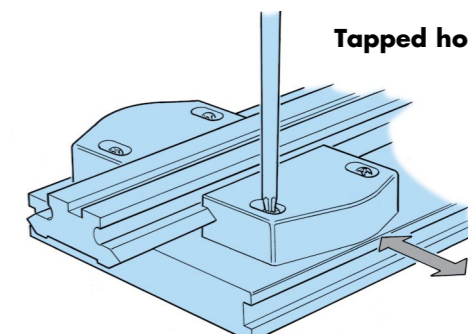

Through hole fixing

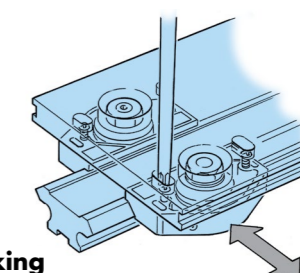

Bearing/Track Roller Adjusting Tools and Tightening Torques

When ordering individual components for the first time, an Adjusting Wrench or Socket Tool should also be ordered - these are only available from Hepco.

Bearing/Roller Type	...13...	...195...	...18...	...265...	...25...	...360...	...34...	...580...	...54...
Adjusting Wrench	AT13	AT18	AT18	AT25	AT25	AT34	AT34	AT54	AT54
Socket Tool	-	RT6	RT6	RT8	RT8	RT10	RT10	RT14	RT14
Fixing Nut Torque	2Nm	7Nm	7Nm	18Nm	18Nm	33Nm	33Nm	90Nm	90Nm

Notes:

- A guide to installation and adjustment of other Hepco components may be found on the relevant individual GV3 catalogue component pages.





Driving and controlling a linear movement with a Hepco AC Geared Motor and Speed Controller 5 is generally far less expensive than using stepper or servo motor systems. Customers are therefore recommended to consider whether the performance and sophistication of their application can be satisfied by Hepco's AC drive equipment before opting for more expensive alternatives. To aid this decision, the following information is provided to explain what can be achieved by using a Hepco AC Geared Motor and Speed Controller. The drawing below shows the switch control for a typical point to point linear movement, with security switches and crash protection devices in place. Additional speeds during the stroke cycle can be achieved by adding more switches wired through to the controller.

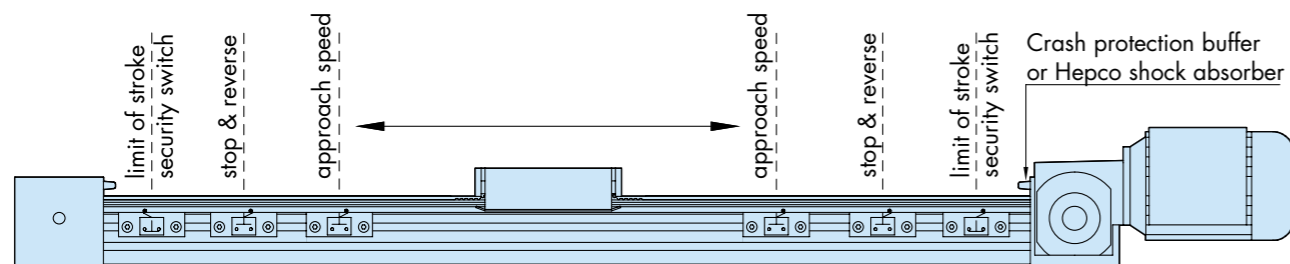

Function and Performance

The AC system can stop, start, reverse, accelerate and decelerate. Dynamic braking of the motor is also possible. In conjunction with a simple PLC, it can dwell at any switch position and perform more sophisticated accelerations, as well as giving output command signals to other equipment.

The signals for initiating the basic functions are provided by means of either mechanical or inductive switches, which are available from Hepco (see 5).

Stop position repeatability can be better than 1mm, and is dependent upon slowing down to a low approach speed before reaching the stop switch. If the approach speed is too fast for the load being carried, the motor will overrun the stop switch position.

Several individual preset speeds can be selected, each with its own acceleration/deceleration profile. These speeds are variable over a very wide range and can be easily set.

The AC system is a simple, reliable, low cost method of driving and control but it does not have the facility for continuous feedback to regulate the exact position of the movement at all times. Continuous feedback is necessary if monitoring and control of the precise dynamic relationship of two or more axes of a machine is required, or if it is necessary to perform a specific dynamic profile with very accurate repeatability. Continuous feedback is a feature of servos and some stepper motor systems.

Fail-Safe Requirements

In the specification of any powered linear system, it is necessary to consider the consequences of system failure. Failure to stop at the end of stroke may result in damage to the system and/or other equipment, and could also present a safety hazard.

It is therefore recommended that the linear transmission includes two levels of safety:

- 1. Limit of stroke security switches** - These should be fitted outboard of the normal end of stroke switches in order to switch off the motor should the linear transmission travel beyond the operating limits which have been set.
- 2. Crash protection** - It is recommended that devices be fitted at the limit of physical travel to absorb the energy of the moving load in the event of high speed overrun of the switches.
GV3 End Stops are recommended (see 32).

Additional Safety Considerations

In many applications, the standard AC motor can be used to dynamically brake the system. In some applications, particularly lifting, a holding brake may also be required. This provides an additional degree of safety and may be used as part of the normal operating cycle. In these cases, the optional braked AC motor should be specified.

Hepco GV3 linear motion components are often incorporated into larger machines. Depending on the application, there may be potential hazards which need to be considered and addressed as appropriate, such as guarding of high speed movements and elimination of hazards due to electrical shock or malfunction.

If the driving force is provided by a reinforced toothed belt or other means of transmission, which could snap beyond a certain load, the customer should ensure that loads approaching the maximum limit will not be exceeded under any circumstances, or that no safety hazard will result from such breakage.



Hepco can supply the speed controller and switches necessary to position and dynamically control linear movement.

AC Speed Controllers

The model and details of the AC Speed Controller will depend on the application. Each type has been selected to match the requirements of the range of AC Geared Motors, and the functionality that is required in point to point linear applications using rack or belt transmissions.

Please contact Hepco for technical advice and to request full details on each model of AC Speed Controller.

The units have the following characteristics, which make them ideally suited for use within AC linear positioning systems:

- Ideally suited for Hepco Rack Driven and Belt Driven systems.
- Available from Hepco at a competitive price.
- Units are manufactured by a leading international supplier, with full support in all major markets.
- Drives from 0.37 - 1.5 kW will power a wide range of three-phase AC induction motors.
- Speeds, acceleration rates, power boost functions and motor braking may be programmed.
- Environmental protection to IP20. Controllers can be located inside an enclosure to achieve any higher rating.
- Keypad programming and digital display of program and running parameters.
- Easy to install and commission.
- Compact unit may be panel mounted or fixed onto a DIN rail.
- Options allow for analogue control via a voltage input or potentiometer, or via digital preset speeds which can be menu programmed or accessed via external switches or a separate PLC.
- Drives are available to run from 230-250 V single-phase or 380-460 V three-phase supplies.
- Units will be supplied with filters to meet the requirements of the EU EMC directive.
- Units may be specified with Devicenet compatible interface for high level control communications.
- On board diagnostics for easy fault finding.
- The simple and economical solution for basic point to point linear positioning applications.

Motor Sizes	Required Controller Power
80 L/2	1.5 kW
80 S/2 & 80 L/4	0.75 kW
80 S/4 & 71 L/2	0.55 kW
71 L/4, 71 S/2 & 71 S/4 all 56 & 63 frame motors	0.37 kW

Limit Switches

In addition to the AC Speed Controller, Hepco supplies mechanical and inductive limit switches, sealed to IP67. These will usually be required as part of the control hardware of a typical installation.

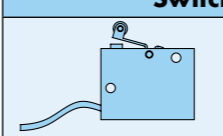
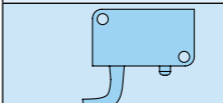
Switch Description	Part Number	Lead Length
 Standard V3 pattern Roller actuated micro-switch	DLS-V7SWM	500mm
 Standard V3 pattern inductive switch	DLS-V7SWI	500mm

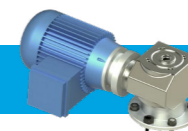

Hepco Gearboxes, AC Geared Motors & Drive Flanges provide a means to drive Rack Driven Carriages and can also be used with separate Racks or Rack Cut Single Edge Spacer Slides to provide a simple and easily adjustable linear drive. The Drive Flange, which connects the Gearbox to the Carriage, incorporates a micro-adjustment facility for achieving correct engagement of the Pinion with the Rack. Customers using the Drive Flange in conjunction with a Carriage of their own construction will need to provide a keyway to accommodate the sliding key portion P1. Please refer to Rack Driven Carriages in the GV3 catalogue for the principle.

To obtain the best performance from the Rack and Pinion drive, it is important that meshing teeth are lubricated. A No.2 lithium soap-based grease is recommended for this purpose. In dirty environments, it is advisable to guard against ingress of debris. When sold separately, Worm Gearboxes have an input flange and shaft coupling which will be tailored to suit the shaft and face details of the customer's motor.

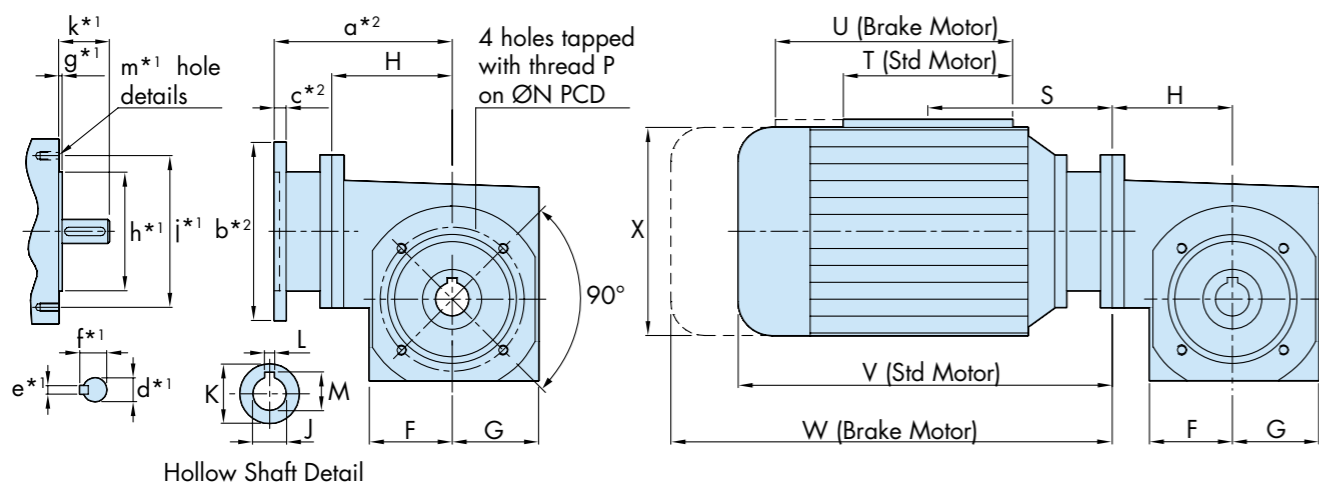

Gearbox Part Number	A	B	C	D	E	F	G	H	J	K	L	M	N	P		Q	R	Gearbox Rated Output Torque	Available Ratios	Weight of Gearbox with Input Flange for Motor
	Ø		Depth																	
WG3	72	75	77	38	33	39	41	57	15	25	5	17.3	62.5	M5	10	67	69	17Nm (typical)	5,7,10,12,15,18,24,30,38,50,75:1	1.6kg
WG4	76	80	82	48	40	49	51	71	20	35	6	22.8	85	M6	12	85	76	32Nm (typical)	6,7.5,8,10,12,15,20,25,30,40,50,60,70,80:1	2.5kg

Motor Frame Size*4	Use with	S	T	U	V	W	X	Y	Z	Power				Weight of AC Geared Motor					
										2 Pole 'S'		2 Pole 'L'		4 Pole 'S'		4 Pole 'L'		'S' Motor	'L' Motor
										90W	120W	60W	90W	180W	250W	120W	180W	kg	kg
56	WG3	60	90	130	167	210	111	100	109	90W	120W	60W	90W	4.5kg	4.7kg				
63	WG3	90	125	165	212	272	123	100	113	180W	250W	120W	180W	4.8kg	5.3kg				
	WG4	99	134	174	221	281													
71	WG3	90	125	165	237	297	138	110	125	370W	550W	250W	370W	6.8kg	7.8kg				
	WG4	99	134	174	246	306													

Drive Flange Part Number	Use With	A1	B1	C1	D1	E1	F1	G1	H1	J1	K1	L1	M1	N1	P1	Q1	R1	S1	T1	Weight
		WG3...	118	35	75	63	75	9	2	49	14	M5	5	6	48	20	2	4	57	43
WG4...	147	34.5	100	88.8	88.8	9	5	62.8	17	M6	6	6	70	25	3	5	76	57	0.5 kg	

The AC Geared Motor and Worm Gearbox may be mounted onto a Rack Driven Carriage in any one of the eight configurations shown below. The terminal box may take one of four positions A...D and the cable exits also have four possible positions 1...4. Please use the diagram below as a guide to selection.

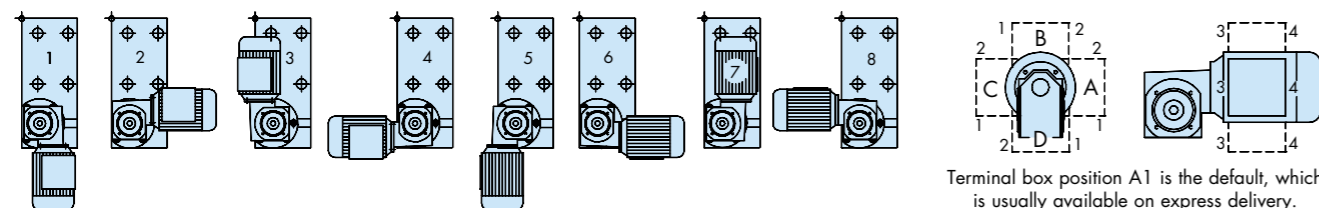

- Notes:**
- The customer's motor dimensions marked *1 on the drawing should be advised to Hepco when the input motor flange option is required.
 - The Gearbox input flange dimensions marked *2 on the drawing will be advised to the customer by Hepco once motor details (see above) have been given.
 - Other motor sizes beyond those listed are available from Hepco, but may not be compatible with the Drive Flange. Please consult Hepco.

Gearboxes and Geared Motors may be specified with an adjustable torque limiting clutch, if required. Hepco supplies three-phase squirrel cage type AC motors to VDE 0530, supported by DIN 42677. Motors in IEC frame sizes 56, 63 and 71 can be supplied, each with the choice of short or long field windings and two pole and four pole designs, running at approximately 2,800 and 1,400 rpm, respectively. Power ratings from 60W to 0.55kW are available. Motors are rated at 400/230V, protected to IP54, and are finished in blue epoxy paint as standard. Fitted disk brakes, alternative single and three phase windings, special finishes and enhanced IP protection rating are available on request. The AC Geared Motor can be combined with the Hepco AC Speed Controller to provide a complete drive control system. Please see 8-9 for details on linear drive performance.

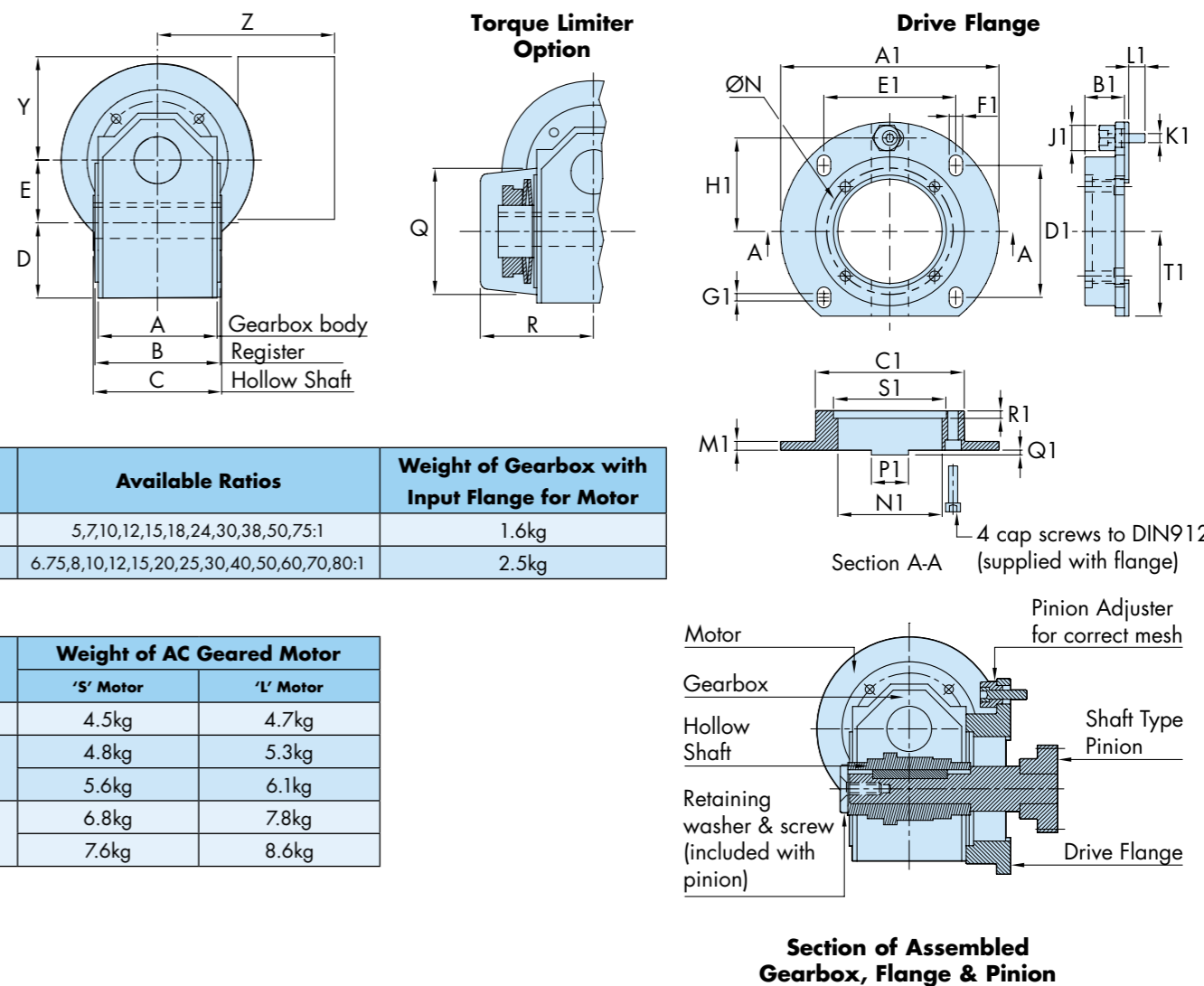

Ordering Details for AC Geared Motor & Worm Gearbox

Part Number **WG3 R30 (T) (4) M 56 (L) (2) (B) (A) (1)**

Gearbox Reduction Ratio (**R30** = 30:1)
T = Optional Torque Limiter
 Leave blank if not required
 Gearbox mounting position
 Choose 1-8 or leave blank for unassembled
 Input Options: **F** = Flange*1,2, **M** = fitted AC Motor

Cable Exit Position: choose **1-4**
 Terminal Box Position: choose **A-D**
B = Brake Motor
 Leave blank if not required
 Motor Poles: **2** = ~2800RPM or **4** = 1400RPM
 Motor field winding: **S** = short or **L** = long
 Motor frame size: **56, 63** or **71***4

These items only apply if an AC motor is required.

Drive Flange* Please state part number as second line of the order (see table above left)
Shaft Pinion* Please state part number as third line of the order (see 27)

* Customers requiring a Geared Motor or Worm Gearbox for use with Rack Driven Carriages should not specify a Drive Flange or Shaft Pinion, as they are included as standard.

CAD

GV3 Catalogue
Rack Driven Carriages

GV3 Catalogue
Racks

GV3 Catalogue
Spacer Slides

Gearbox, Motor & Flange 6

Speed Controller 5

Shaft Type Pinion 27

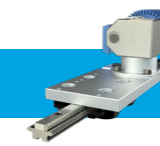

The following section should be used by customers who require a system using a Rack Driven Carriage with fitted Gearbox or Geared Motor, and need to calculate the speeds and forces produced by the system. Drive calculations for systems using Hepco Belt Driven Carriages, belts and pulleys are identical to those in the Hepco DLS Driven Linear System catalogue. Customers using other combinations of components should use the data within this document and conventional calculations to rate their systems. Hepco will be pleased to assist in this selection process, on request.

How to select the right Rack Driven Carriage + Geared Motor combination

The method of rating detailed below uses a simplified version of the definitive calculations. It will select the correct system in the vast majority of cases. For unusual and borderline cases, the application may be referred to Hepco for a more precise rating.

To choose the right system configuration for a given duty, follow the three stages outlined below:

- Choose the size of Rack Driven Carriage required, considering the following factors: i) The load to be supported by the Carriage (see Load/Life Calculations section in the GV3 catalogue for details of rating); ii) the linear force which is required (an AURD...34... has a maximum rated linear force of 400 N, while for an AURD...54... this figure is typically 600-700 N, depending on the gear ratio); and iii) the physical dimensions of the unit (see Rack Driven Carriages section in the GV3 catalogue).
- The user should then examine the relevant table to identify combinations of motor size, number of poles and gearbox ratio which have a suitable working speed range and linear driving force. If a unit is intended to run at a single speed, it is recommended that a unit with a nominal speed close to the working speed is chosen.
- In many cases, there will be more than one combination which will satisfy the speed and force requirements. In these cases, the following secondary factors may be considered:
 - For arduous applications, it is best to select the combination with the highest rated linear force for the gears.
 - For gearbox ratios of less than 29:1, the motor can be back-driven through the gearbox. This may be useful as it will allow the axis to be manually positioned with the power switched off. In some cases, however (for instance in lifting applications) back-driving may be undesirable. If this is the case, specify the electro-magnetic brake option or select a higher gearbox ratio.
 - Two pole motors will be lighter than four pole for a given power.
 - For best dynamic performance, use a four pole motor. This will give sharper acceleration and more dynamic performance than a two pole motor driving through a gearbox with a higher ratio. For a given load, a more powerful motor will generally accelerate the system more quickly than a less powerful one, but the benefit of increasing power will be small if loads are light.
 - Four pole motors keep the speed in the gearbox down, minimising heating and maximising life.
 - The marginal cost of extra motor power is low on an AC system. If in doubt between two sizes, it is often best to specify larger, as there will usually be only a small extra cost.

How to select the right Rack Driven Carriage + Gearbox combination

The approach is similar to that used when selecting the AC Geared Motor.

The actual linear force which is generated by the system will depend on the torque generated by the motor, the gearbox efficiency, the Rack and Pinion drive efficiency, the reduction ratio, and the Carriage friction. This can be calculated using the following equation:

$$\text{Linear Force (N)} = \left(\frac{\tau_m \times \eta_g \times \eta_r \times R_r}{P_r} \right) - F_c$$

The parameters used are described below:

τ_m is the torque generated by the motor in Nm

η_g is the Gearbox efficiency (this varies between ratios and speeds, but is typically 0.9 - 0.75. Contact Hepco for full data.

η_r is the Rack and Pinion drive efficiency (~0.9)

R_r is the gearbox reduction ratio

P_r is the Pinion radius in metres (= 0.021 m for the AURD ...34... and = 0.027 m for the AURD...54...)

F_c is the Carriage friction in Newtons (~25 N for the AURD ...34... and ~40 N for the AURD ...54...)

The linear force which can be generated by the Rack Driven Carriage will be limited by the lowest of the Rated Linear Force for the gears, Bearings and Rack & Pinion (as detailed in the tables 9). Customers should ensure that the motor torque selected does not overload the mechanical components.

AURD...34... with WG3 AC Geared Motor/Gearbox												
Nominal Speed m/s at 50Hz*1	Motor Poles	Gear Ratio	Travel per motor rev/mm	Nominal Linear Force/N for system with motor size*1						Rated Linear Force (N) For Critical Components*2		
				56S	56L	63S	63L	71S	71L	Gears	Bearings	Rack & Pinion
1.23	2	5	26.4	35	56	99	146	228	348	440	740	400
0.88	2	7	18.8	61	91	142	211	322		498	740	400
0.62	2	10	13.2	90	129	211	301	448		526	740	400
0.59	4	5	26.4	56	99	138	219	309	446	483	740	400
0.51	2	12	11.0	112	159	245	356			541	740	400
0.42	4	7	18.8	86	142	202	309	446		543	740	400
0.41	2	15	8.8	138	192	301	446			526	740	400
0.35	2	18	7.3	168	232	365				511	740	400
0.29	4	10	13.2	129	206	292	446			573	740	400
0.26	2	24	5.5	217	298					526	740	400
0.25	4	12	11.0	155	245	344				588	740	400
0.21	2	30	4.4	258	352					511	740	400
0.2	4	15	8.8	189	296	446				573	740	400
0.16	2	38	3.5	323	440					529	740	400
0.16	4	18	7.3	224	348					558	740	400
0.13	2	50	2.6	376						416	740	400
0.12	4	24	5.5	284	446					573	740	400
0.1	4	30	4.4	331						573	740	400
0.08	4	38	3.5	446						603	740	400

AURD...54... with WG4 AC Geared Motor/Gearbox										
Nominal Speed m/s at 50Hz*1	Motor Poles	Gear Ratio	Travel per motor rev/mm	Nominal Linear Force/N for system with motor size*1				Rated Linear Force (N) For Critical Components*2		
				63S	63L	71S	71L	Gears	Bearings	Rack & Pinion
1.17	2	6.75	25.1	86	140	227	360	539	700	950
0.99	2	8	21.2	110	167	267	427	630	700	950
0.79	2	10	17.0	147	220	360	527	666	700	950
0.66	2	12	14.1	177	260	427	627	630	700	950
0.57	4	6.75	25.1	126	217	327	460	602	700	950
0.53	2	15	11.3	227	360	499	762	648	700	950
0.48	4	8	21.2	163	263	360	560	703	700	950
0.4	2	20	8.5	302	435	662		666	700	950
0.38	4	10	17.0	210	360	460	693	743	700	950
0.32	2	25	6.8	362	518			612	700	950
0.32	4	12	14.1	247	393	560		703	700	950
0.27	2	30	5.7	436	622			648	700	950
0.25	4	15	11.3	327	493	693		723	700	950
0.2	2	40	4.2	547	775			648	700	950
0.19	4	20	8.5	427	660			743	700	950
0.16	2	40	3.4	674				703	700	950
0.15	4	25	6.8	493	760			683	700	950
0.13	4	30	5.7	593				723	700	950
0.1	4	40	4.2	727				723	700	950

Notes:

- Rack Driven Carriages with AC Geared Motor will produce the Nominal Linear Force at speeds ranging from 50 to 120% of the Nominal Speed. Units will perform with a lower force and duty cycle over a much wider speed range from 10% to 180% of the Nominal Speed.
- There are three mechanical elements which limit the driving force which can be generated by a Rack Driven Carriage. These are:
 - The torque capacity of the gears within the gearbox (based on a service factor of 1.4, which corresponds to fast operation for 8 hours per day). Allowable forces may be either increased or reduced for duties which are less or more severe than this.
 - The load capacity of the gearbox bearings. The torque reaction has been calculated assuming the Pinion diameter and shaft length of the Rack Driven Carriage. For other designs, the linear force will be different.
 - The continuous linear force rating for a well lubricated Rack and Pinion.

In each of the tables, all of these figures are shown (for the benefit of those using components in other ways), but the smallest of the three factors will limit the performance for Rack Driven Carriage applications. This limiting factor is shown in **bold** text.

Some of the combinations of AC Motor and Gearbox produce a linear force which is higher than the limiting mechanical element is rated for. These combinations are shown in **blue** text. These combinations may be permissible, depending on the duty. Please contact Hepco for details.

The formula and values in the following examples are detailed in the Load/Life Calculations section of the GV3 catalogue.

Example Calculation 1

A machine control unit is mounted onto a Hepco AU 76 34 L240 CS DR Carriage (Standard Carriage with fitted Cap Seals and Double Row Bearings), mounted onto an NM76 P1 Double Edge Spacer Slide. The weight of the control unit and Carriage is 45 kg, and the centre of mass is central along the length of the Carriage, and 0.085m from the Slide 'V' as shown in the diagram.

The system is lubricated.

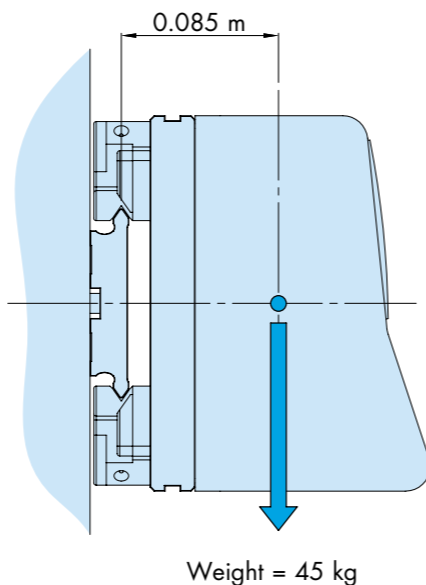

Calculating the Carriage life:

(Refer to 50-51 of the Load/Life Calculations section within the GV3 catalogue.)

$$L_1 = M = Mv = 0$$

$$L_2 = 45 \text{ kg} \times 9.81(\text{gravity}) = 441.5 \text{ N} \quad M_s = 441.5 \times 0.085 = 37.5 \text{ Nm}$$

$$L_f = \frac{L_1}{L_{1(\max)}} + \frac{L_2}{L_{2(\max)}} + \frac{M_s}{M_{s(\max)}} + \frac{Mv}{Mv_{(\max)}} + \frac{M}{M_{(\max)}}$$

$$L_f = \frac{0}{3600} + \frac{441.5 \text{ N}}{6000 \text{ N}} + \frac{37.5 \text{ Nm}}{130 \text{ Nm}} + \frac{0}{3000 \times D} + \frac{0}{1800 \times D} = 0.362$$

$$\text{Life} = \frac{\text{Basic Life}}{(0.03 + 0.97L_f)^3} = \frac{250}{(0.03 + 0.97 \times 0.362)^3} = \mathbf{4,508 \text{ km}}$$

Example Calculation 2

An overhead transfer system uses a combination of an NLE P3 Single Edge Spacer Slide and an FT 66 33 P3 Flat Track on either side of a machine bay. 2 off LJ54CDR Bearings with CS54 Cap Seals run on the 'V' Slide. 2 off LR54C Track Rollers run on the Flat Track. A single LRN54E Narrow Track Roller is on the non-loaded side of both the 'V' Slide and Flat Track to retain the moving structure on the Slides.

A weight of 420 kg is located centrally on the structure, such that the load is equally distributed between the LJ54's and LR54's, each therefore experiencing a radial load of $9.81 \times 105 = 1030 \text{ N}$.

The system is lubricated.

Calculating the life of each LJ54CDR Bearing:

(Refer to 50-51 of the GV3 catalogue.)

$$L_A = 0 \quad L_R = 1030 \text{ N}$$

$$L_f = \frac{L_A}{L_{A(\max)}} + \frac{L_R}{L_{R(\max)}} = \frac{0}{2500} + \frac{1030 \text{ N}}{5000 \text{ N}} = 0.206$$

$$\text{Life} = \frac{\text{Basic Life}}{(0.03 + 0.97L_f)^3} = \frac{500}{(0.03 + 0.97 \times 0.206)^3} = \mathbf{41,186 \text{ km}}$$

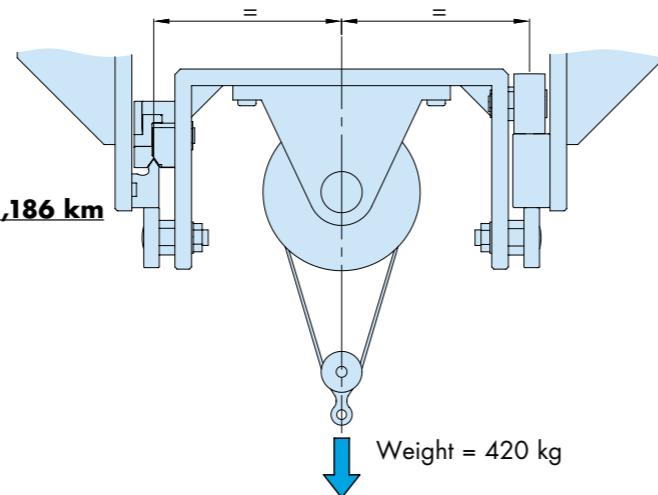

Calculating the life of each LR54C Track Roller:

(Refer to page 52 of the GV3 catalogue.)

$$L_A = 0 \quad L_R = 1030 \text{ N}$$

$$L_f = \frac{L_R}{L_{R(\max)}} = \frac{1030 \text{ N}}{8000 \text{ N}} = 0.129$$

$$\text{Life} = \frac{1000}{L_f^3} = \frac{1000}{0.129^3} = \mathbf{468,484 \text{ km}}$$

From this it can be seen that the 'V' Bearings are the life determining factor for the system as a whole.

Example Calculation 3

A machine vertical movement uses a Hepco AU 60 360 L280 Carriage (Slimline Carriage without Cap Wipers or Lubricators) mounted onto an NM60... P3 Double Edge Spacer Slide. The Slide system is run in a dry condition and is raised and lowered by a ball screw, as shown. The total mass being raised and lowered is 14 kg.

The load F1 due to the weight of $14 \text{ kg} \times 9.81 = 137.4 \text{ N}$ is balanced out by the force F2 of the ball screw, so no direct load is put onto the Slide system. There is a moment load in the M direction which is calculated by taking moments about the Slide 'V'.

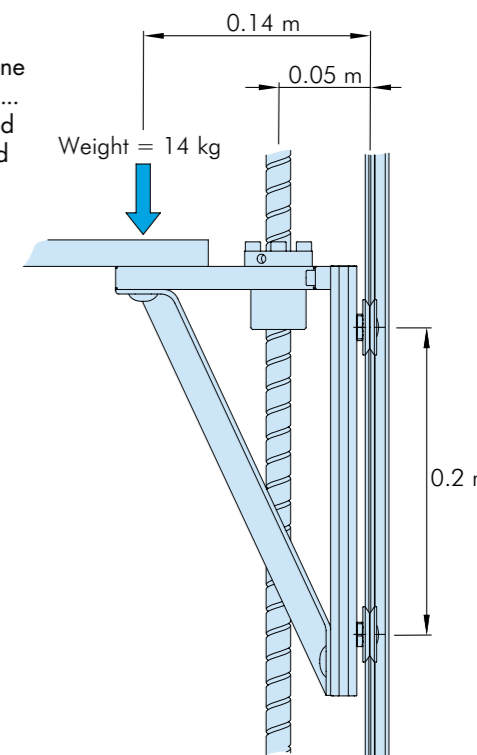

Calculating the Carriage life:

(Refer to 50-51 of the GV3 catalogue.)

$$M = (137.4 \text{ N} \times 0.14 \text{ m}) - (137.4 \text{ N} \times 0.05 \text{ m}) = 12.4 \text{ Nm}$$

$$L_1 = L_2 = M_s = Mv = 0$$

$$L_f = \frac{0}{800} + \frac{0}{800} + \frac{0}{22} + \frac{0}{400 \times 0.2} + \frac{12.4}{400 \times 0.2} = 0.155$$

$$\text{Life} = \frac{\text{Basic Life}}{(0.03 + 0.97L_f)^2} = \frac{100}{(0.03 + 0.97 \times 0.155)^2} = \mathbf{3,091 \text{ km}}$$

Example Calculation 4

A testing machine has a horizontal table movement that uses 2 off NVE...P1 Single Edge Spacer Slides with 2 off BHJ 18 C NS and 2 off BHJ 18 E NS Blind Hole Standard Bearings. Lubrication is provided by 2 off LB18F Lubricators.

The table includes a casting, and the weight is 10 kg, which is centrally located with respect to the four Bearings.

When the table is moving, there is an external load of 50 N, which is exerted as shown in the diagram.

The weight of the table exerts a force $10 \text{ kg} \times 9.81 = 98.1 \text{ N}$.

This is equally shared between all four Bearings, so each sees an axial load of 24.5 N.

The external force of 50 N is shared by the two concentric Bearings. Each sees a radial load of 25 N.

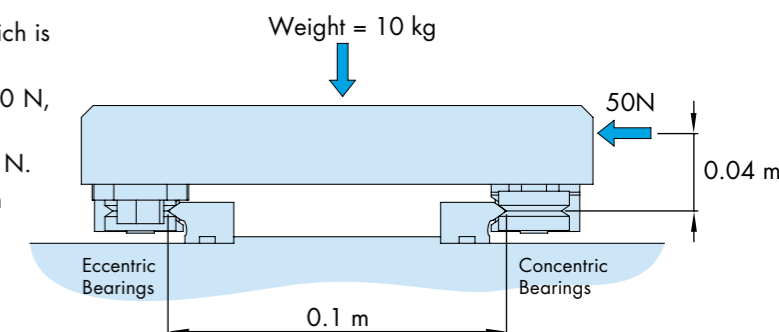

The external force also exerts a turning moment which will be balanced by additional axial reaction forces on the Bearings.

Taking moments about the 'V' of the concentric side (ignoring the weight reactions which will cancel out) we get:

$$\text{Counter-clockwise moment: } 50 \text{ N} \times 0.04 \text{ m} = 2 \text{ Nm}$$

$$\text{Clockwise moment: } 2 \times (\text{reaction force on each eccentric Bearing}) \times 0.1 \text{ m}$$

$$\text{Since clockwise moment} = \text{counter-clockwise moment, then reaction force on each eccentric Bearing} = \frac{2 \text{ Nm}}{2 \times 0.1 \text{ m}} = 10 \text{ N}$$

Since there is no unbalanced vertical force, the axial reaction on each concentric Bearing will be equal and opposite, i.e. -10 N.

The load on each concentric and eccentric Bearing is therefore as follows:

$$\text{Each Concentric Bearing: } L_A = 24.5 - 10 = 14.5 \text{ N} \quad L_R = 25 \text{ N}$$

$$\text{Each Eccentric Bearing: } L_A = 24.5 + 10 = 34.5 \text{ N} \quad L_R = 0$$

Calculating the Bearing life:

(Refer to 50-51 of the GV3 catalogue.)

$$L_f = \frac{L_A}{L_{A(\max)}} + \frac{L_R}{L_{R(\max)}}$$

$$L_f \text{ (for concentrics)} = \frac{14.5 \text{ N}}{125 \text{ N}} + \frac{25 \text{ N}}{200 \text{ N}} = 0.241$$

$$L_f \text{ (for eccentrics)} = \frac{34.5 \text{ N}}{125 \text{ N}} + \frac{0}{200 \text{ N}} = 0.276$$

The Bearing life for the more heavily loaded eccentric Bearings is calculated as shown below:

$$\text{Life} = \frac{\text{Basic Life}}{(0.03 + 0.97L_f)^3} = \frac{100}{(0.03 + 0.97 \times 0.276)^3} = \mathbf{3,782 \text{ km}}$$

When GV3 Slide Beams and Spacer Slides are used as self-supporting beams (as shown in Application Examples section of the GV3 catalogue), the Slides will deflect under load and their own weight. Care should be taken when designing an installation to take account of this deflection, by choosing a Slide or Slide Beam which will give both adequate life and satisfactory stiffness for the duty.

The deflection of a Slide or Slide Beam across a span (as shown, right) will be a maximum at the centre of the span when the load passes over this point. This maximum deflection is given by equation (1):

$$(1)^{*2,3} \quad d = \underbrace{\frac{FL^3}{48EI}}_{\text{Deflection due to the applied load}} + \underbrace{\frac{5L^4Qg}{384EI}}_{\text{Deflection due to the Slide or Slide Beam's weight}}$$

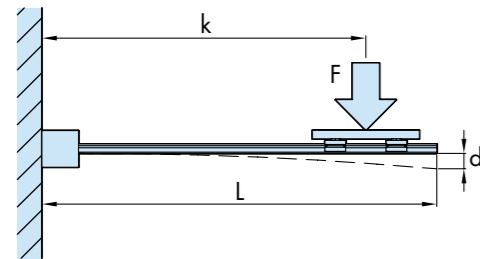
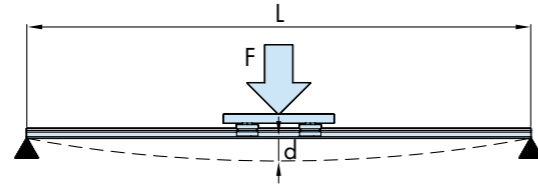

The deflection of a Slide or Slide Beam acting as a cantilever will be a maximum at the free end when the load is at the outermost extremity of its stroke. This maximum deflection is given by equation (2)*1:

$$(2)^{*1, 2 \& 3} \quad d = \underbrace{\frac{FL^2(3L-k)}{6EI}}_{\text{Deflection due to the applied load}} + \underbrace{\frac{L^4Qg}{8EI}}_{\text{Deflection due to the Slide's weight}}$$

In the equations (1) and (2) above, L, k and d are the dimensions shown in the relevant diagrams (in mm) and F is the load applied (in Newtons). The term EI is the product of the Slide or Slide Beam material's Young's modulus and the section moment of inertia, which is a constant, relating to the stiffness of the Slide section in the orientation of the application.

The term Q is the mass of the Slide in kg/mm and g is the acceleration due to gravity (=9.81m/s²).

The values of EI and Q for the various sections are given in the table below:

Slide Part Number	EI (Section Stiffness - Nmm ²)		Q = Section Mass kg/mm
	Horizontal*3	Vertical*3	
NS 25...	4.2 x 10 ⁸	1.2 x 10 ⁹	0.0015
NS 35...	7.5 x 10 ⁸	4.6 x 10 ⁹	0.0023
NS 50...	1.1 x 10 ⁹	1.55 x 10 ¹⁰	0.0032
NM 44...	1.7 x 10 ⁹	9.8 x 10 ⁹	0.0035
NM 60...	2.6 x 10 ⁹	3 x 10 ¹⁰	0.0055
NM 76...	3.4 x 10 ⁹	6.8 x 10 ¹⁰	0.007
NL 76...	1.1 x 10 ¹⁰	8.6 x 10 ¹⁰	0.010
NL 120...	1.8 x 10 ¹⁰	4.3 x 10 ¹¹	0.015

Slide Beam Part Number	EI (Section Stiffness - Nmm ²)		Q = Section Mass kg/mm
	Horizontal*3	Vertical*3	
SB S 35...	5.8 x 10 ¹⁰	9.5 x 10 ¹⁰	0.0068
SB S 35...L...(lightweight)	3.2 x 10 ¹⁰	5.6 x 10 ¹⁰	0.0043
SB S 50...	5.8 x 10 ¹⁰	1 x 10 ¹¹	0.0072
SB S 50...L...(lightweight)	3.2 x 10 ¹⁰	6.2 x 10 ¹⁰	0.0047
SB M 44...	1.5 x 10 ¹¹	2.1 x 10 ¹¹	0.0104
SB M 60...	1.5 x 10 ¹¹	2.3 x 10 ¹¹	0.0112
SB M 76...	1.5 x 10 ¹¹	2.5 x 10 ¹¹	0.0129

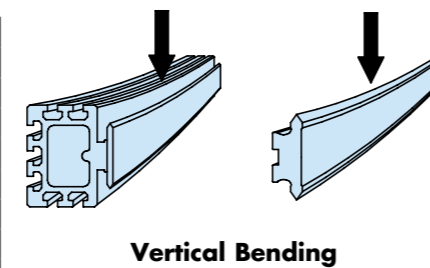
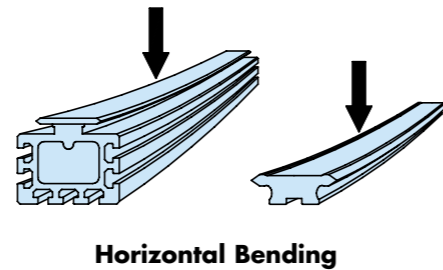

Notes:

- The calculation for the deflection of a cantilevered Slide assumes that the Slide is held absolutely rigidly at one end. This is often difficult to achieve in practice, and it is usual to allow for additional deflection due to the compliance of the support. Hepco will supply such data on Flange Clamps, on request.
- The deflections calculated are for static loads. In some situations, dynamic loading may increase the amount of bend.
- For maximum stiffness, the Slide or Slide Beam section should be arranged such that the bending mode with the higher value for EI resists bending. Care should be taken in such applications to ensure that offset loads do not cause excessive bending in the weaker perpendicular plane.

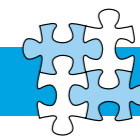

Customers can design a system to meet their exact requirements by combining components as indicated in the 'Mix & Match' compatibility table below.

Part Number	'Mix & Match' Component Compatibility Chart																									
	✓ = Preferred choice										✓ = Compatible															
	...J13...	...J18...	...J25...	...J34...	...J54...	CS18	CS25	CS34	CS54	LB12	LB20	LB25	LB44	LB76	...J195...	...J265...	...J360...	...J580...	CW195	CW265	CW360	CW580	LB195	LB265	LB360	LB580
NMS 12...	✓	✗	✗	✗	✗	✗	✗	✗	✗	✓	✗	✗	✗	✗	✓	✗	✗	✗	✗	✗	✗	✗	✗	✗	✗	✗
NV 20...	✓	✓	✓	✓	✗	✓	✗	✗	✗	✓	✓	✓	✗	✗	✓	✓	✗	✗	✓	✗	✗	✗	✓	✓	✗	✗
NV 28...	✓	✓	✓	✓	✗	✓	✗	✗	✗	✓	✓	✓	✗	✗	✓	✓	✗	✗	✓	✗	✗	✗	✓	✓	✗	✗
NS 25...	✓	✓	✓	✓	✗	✓	✗	✗	✗	✓	✓	✓	✗	✗	✓	✓	✗	✗	✓	✗	✗	✗	✓	✓	✓	✗
NS 35...	✓	✓	✓	✓	✗	✓	✗	✗	✗	✓	✓	✓	✗	✗	✓	✓	✗	✗	✓	✗	✗	✗	✓	✓	✓	✗
NS 50...	✓	✓	✓	✓	✗	✓	✗	✗	✗	✓	✓	✓	✗	✗	✓	✓	✗	✗	✓	✗	✗	✗	✓	✓	✓	✗
NM 44...	✓	✓	✓	✓	✓	✓	✓	✗	✗	✓	✓	✓	✗	✗	✓	✓	✗	✗	✓	✗	✗	✗	✓	✓	✓	✓
NM 60...	✓	✓	✓	✓	✓	✓	✓	✗	✗	✓	✓	✓	✗	✗	✓	✓	✗	✗	✓	✗	✗	✗	✓	✓	✓	✓
NM 76...	✓	✓	✓	✓	✓	✓	✓	✗	✗	✓	✓	✓	✗	✗	✓	✓	✗	✗	✓	✗	✗	✗	✓	✓	✓	✓
NL 76...	✓	✓	✓	✓	✓	✓	✓	✓	✓	✓	✓	✓	✗	✗	✓	✓	✓	✗	✗	✗	✗	✓	✓	✓	✓	✓
NL 120...	✓	✓	✓	✓	✓	✓	✓	✓	✓	✓	✓	✓	✗	✗	✓	✓	✓	✗	✗	✗	✗	✓	✓	✓	✓	✓
NMS E...	✓	✗	✗	✗	✗	✗	✗	✗	✗	✓	✗	✗	✗	✗	✓	✗	✗	✗	✗	✗	✗	✗	✓	✗	✗	✗
NV E...	✓	✓	✓	✓	✗	✓	✗	✗	✗	✓	✓	✗	✗	✗	✓	✓	✗	✗	✓	✗	✗	✗	✓	✓	✗	✗
NS E...	✓	✓	✓	✓	✗	✓	✗	✗	✗	✓	✓	✓	✗	✗	✓	✓	✗	✗	✓	✗	✗	✗	✓	✓	✓	✗
NM E...	✓	✓	✓	✓	✓	✓	✓	✗	✗	✓	✓	✓	✗	✗	✓	✓	✗	✗	✓	✗	✗	✗	✓	✓	✓	✓
NL E...	✓	✓	✓	✓	✓	✓	✓	✓	✓	✓	✓	✓	✗	✗	✓	✓	✓	✗	✗	✗	✗	✓	✓	✓	✓	✓
MS 12...	✓	✓	✗	✗	✗	✗	✗	✗	✗	✓	✗	✗	✗	✗	✓	✗	✗	✗	✗	✗	✗	✗	✓	✗	✗	✗
V 20...	✓	✓	✓	✓	✗	✓	✗	✗	✗	✓	✓	✓	✗	✗	✓	✓	✗	✗	✓	✗	✗	✗	✓	✓	✗	✗
V 28...	✓	✓	✓	✓	✗	✓	✗	✗	✗	✓	✓	✓	✗	✗	✓	✓	✗	✗	✓	✗	✗	✗	✓	✓	✗	✗
S 25...	✓	✓	✓	✓	✓	✓	✗	✗	✗	✓	✓	✓	✗	✗	✓	✓	✗	✗	✓	✗	✗	✗	✓	✓	✓	✗
S 35...	✓	✓	✓	✓	✓	✓	✗	✗	✗	✓	✓	✓	✗	✗	✓	✓	✗	✗	✓	✗	✗	✗	✓	✓	✓	✗
S 50...	✓	✓	✓	✓	✓	✓	✗	✗	✗	✓	✓	✓	✗	✗	✓	✓	✗	✗	✓	✗	✗	✗	✓	✓	✓	✗
M 44...	✓	✓	✓	✓	✓	✓	✓	✗	✗	✓	✓	✓	✗	✗	✓	✓	✗	✗	✓	✗	✗	✗	✓	✓	✓	✓
M 60...	✓	✓	✓	✓	✓	✓	✓	✗	✗	✓	✓	✓	✗	✗	✓	✓	✗	✗	✓	✗	✗	✗	✓	✓	✓	✓
M 76...	✓	✓	✓	✓	✓	✓	✓	✗	✗	✓	✓	✓	✗	✗	✓	✓	✗	✗	✓	✗	✗	✗	✓	✓	✓	✓
L 76...	✓	✓	✓	✓	✓	✓	✓	✓	✓	✓	✓	✓	✗	✗	✓	✓	✓	✗	✗	✗	✗	✓	✓	✓	✓	✓
L 120...	✓	✓	✓	✓	✓	✓	✓	✓	✓	✓	✓	✓	✗	✗	✓	✓	✓	✗	✗	✗	✗	✓	✓	✓	✓	✓
MS E...	✓	✗	✗	✗	✗	✗	✗	✗	✗	✓	✗	✗	✗	✗	✓	✗	✗	✗	✗	✗	✗	✗	✓	✗	✗	✗
VE...	✓	✓	✓	✓	✗	✓	✗	✗	✗	✓	✓	✗	✗	✗	✓	✓	✗	✗	✓	✗	✗	✗	✓	✓	✗	✗
SE...	✓	✓	✓	✓	✓	✓	✗	✗	✗	✓	✓	✓	✗	✗	✓	✓	✗	✗	✓	✗	✗	✗	✓	✓	✓	✗
ME...	✓	✓	✓	✓	✓	✓	✓	✗	✗	✓	✓	✓	✗	✗	✓	✓	✗	✗	✓	✗	✗	✗	✓	✓	✓	✓
LE...	✓	✓	✓	✓	✓	✓	✓	✓	✓	✓	✓	✓	✗	✗	✓	✓	✓	✗	✗	✗	✗	✓	✓	✓	✓	✓

GV3 can be ordered either as individual components or as factory assembled systems. For details on the extensive range of factory assembled Standard, Slimline, Removable, Belt Driven and Rack Driven Carriages, please refer to the GV3 catalogue.

This section includes summary data on Slides, Bearings and Lubrication Devices. They allow customers to calculate the overall dimensions of a system (less the Carriage plate) and provide important reference dimensions including drilling details. The information can be determined for any combination of components as indicated in the Mix and Match table on 13, enabling customers to design a system to meet their exact requirements.

Dimensions in respect of the additional components used in Slide Beams, Belt Driven Carriages and Rack Driven Carriages may also be found on the pages relating to these products in this Technical Guide and the GV3 catalogue.

'V' Slide Systems with Standard 'V' Bearing

Please refer to the diagrams below and the tables 15 when designing a system utilising the Standard Bearing programme. Alternatively, for systems which are based on the Slimline Bearing programme, see 16-17. For systems which incorporate Track Rollers and/or Pinions, see 18-19.

CAD models are also available online.

Slides with Through Hole Fixing Bearings

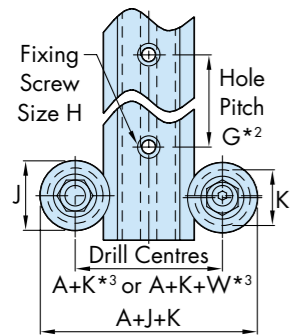

Slides with Blind Hole Fixing Bearings

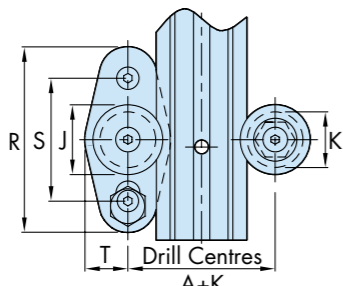

Slides with Cap Seals

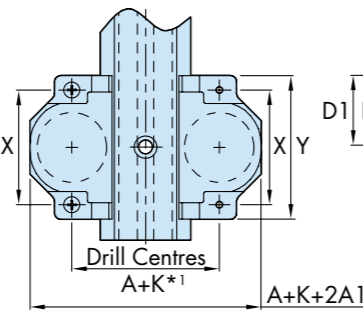

Slides with Lubricators

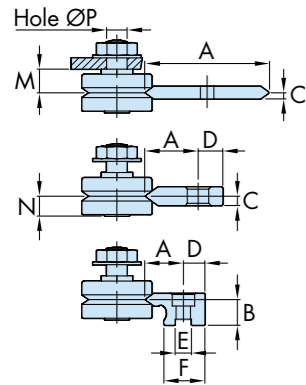
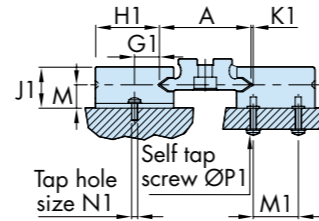
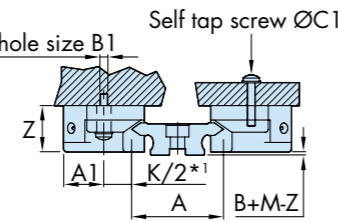
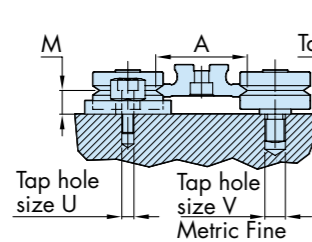
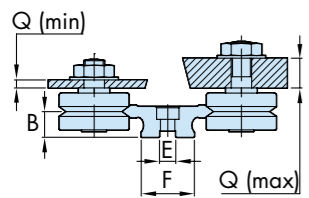
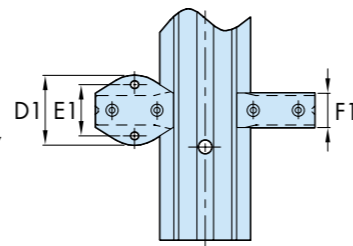

Drilling positions for double eccentric (DE) Bearings*3:

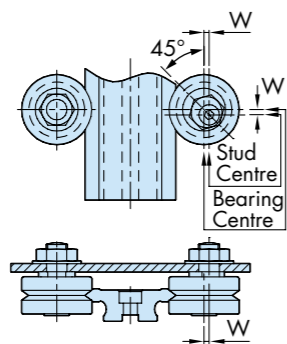

Notes:

- The fixing screw positions for the size CS18 Cap Seal are not on the same centreline as the Bearing. When using the CS18, please add 3.8mm to A+K.
- The NL120 and L120 Slides have two parallel rows of holes.
- Drilling centres A+K apply to all Bearings with the exception of double eccentric (DE) type. If double eccentric Bearings are used with the intention of disengaging the Slide, then drilling centres A+K+W should be used. Double eccentric Bearings are designed to adjust in with the eccentric making a 45° angle to the Slide as shown above.

Part Number	A		B		C		D		E	F		G	H
	P1/P2	P3	P1	P2/P3	P1	P2/P3	P1/P2	P3		P1/P2	P3		
NMS 12...	12.37	13.25	6.2	6.4	-	-	-	-	4	8.5	8.9	45	M3
NV 20...	20.37	21.01	8	8.2	-	-	-	-	5	12	12.4	90	M4
NV 28...	28.37	29.01	8	8.2	-	-	-	-	6	20	20.4	90	M5
NS 25...	25.74	26.58	10	10.2	-	-	-	-	6	15	15.4	90	M5
NS 35...	35.74	36.38	10	10.2	-	-	-	-	8	25	25.4	90	M6
NS 50...	50.74	51.38	10	10.2	-	-	-	-	10	40	40.4	90	M6
NM 44...	44.74	45.58	12.5	12.7	-	-	-	-	8	26	26.4	90	M6
NM 60...	60.74	61.38	12.5	12.7	-	-	-	-	10	42	42.4	90	M8
NM 76...	76.74	77.38	12.5	12.7	-	-	-	-	12	58	58.4	90	M8
NL 76...	76.74	77.58	19.5	19.7	-	-	-	-	15	50	50.4	180	M12
NL 120...	120.74	121.38	19.5	19.7	-	-	-	-	45	94	94.4	180	M10

NMS E...	6.19	6.41	6.2	6.4	-	-	5	5.3	4	9.25	9.65	45	M3
NV E...	9.69	10.02	8	8.2	-	-	6.5	6.7	4	12	12.4	90	M4
NS E...	12.87	13.19	10	10.2	-	-	8.5	8.7	6	16	16.4	90	M5
NM E...	18.87	19.19	12.5	12.7	-	-	10.5	10.7	8	20	20.4	90	M6
NLE...	27.37	27.69	19.5	19.7	-	-	16	16.2	12	30	30.4	180	M10

MS 12...	12.55	13.13	-	-	1.52	1.60	-	-	-	-	-	30	M3
V 20...	20.37	21.01	-	-	2.14	2.21	-	-	-	-	-	90	M4
V 28...	28.37	29.01	-	-	2.14	2.21	-	-	-	-	-	90	M5
S 25...	25.81	26.58	-	-	2.39	2.47	-	-	-	-	-	90	M6
S 35...	35.81	36.58	-	-	2.39	2.47	-	-	-	-	-	90	M6
M 44...	44.81	45.58	-	-	3.14	3.21	-	-	-	-	-	90	M6
M 60...	60.81	61.58	-	-	3.14	3.21	-	-	-	-	-	90	M8
M 76...	76.81	77.38	-	-	3.14	3.21	-	-	-	-	-	90	M8
L 76...	76.81	77.58	-	-	4.56	4.72	-	-	-	-	-	90	M10
L 120...	120.81	121.58	-	-	4.56	4.72	-	-	-	-	-	180*3	M10*3

MS E...	6.87	7.1	-	-	1.52	1.60	4.5	4.7	-	-	-	45	M3
VE...	10.37	10.6	-	-	2.14	2.21	6	6.2	-	-	-	90	M4
SE...	12.96	13.3	-	-	2.39	2.47	6.5	6.7	-	-	-	90	M5
ME...	17.46	17.8	-	-	3.14	3.21	8	8.2	-	-	-	90	M6
LE...	22.46	22.8	-	-	4.56	4.72	10	10.2	-	-	-	90	M8

Part Number	J	K*1	M	N	P	Q (short axle)		Q (long axle)		R	S	T	U	V	W
						Min	Max	Min	Max						
...J13...	12.7	9.51	5.47	4.5	4	2.2	3	2.4	6.7	47.5	30	10	M3	M4x0.5	1.34
...J18...	18	14.0	6.75	5.6	6	2.4	3.4	2.5	10	54	38	12.3	M4	M6x0.75	1.84
...J25...	25	20.27	9.0	7.5	8	2.2	3.8	4.9	13	72	50	16	M5	M8x1	1.95
...J34...	34	27.13	11.5	9.7	10	5.2	6.6	5.9	14.8	90.5	60	21	M6	M10x1.25	2.55
...J54...	54	41.8	19.0	15.6	14	5.7	8.2	7.9	20.4	133	89.5	31	M8	M14x1.5	3.89

Part Number	X	X1	Y	Z	A1	B1	C1	Use with Bearings
CS18	32.5	-	42	13.8	11	M2.5	3	...J18...
CS25	44	-	55	18	16	M3	3.5	...J25...
CS34	56	-	70	22.5	21	M4	4.5	...J34...
CS54	80	-	98	36.5	31	M5	6	...J54...

Part Number	D1	E1	F1	G1	H1	J1	K1	M1	N1	P1	Use with Bearings
LB12	17	12	7	4.8	11.5	10	1.6	6.5	M2.5	2.5	...J13...
LB20	19	13	8	7.3	19	12	0.8	13	M2.5	2.5	...J18...
LB25	25	18	12	9	23	16.5	1	16	M3	3	...J25...
LB44	34	25	17	11.8	31	20	0.8	22	M4	3	...J34...
LB76	50	38	25	17.8	47	33.5	1.3	33	M5	3.5	...J54...



'V' Slide Systems with Slimline 'V' Bearing

Please refer to the diagrams below and the tables 17 when designing a system utilising the Slimline Bearing programme. For systems which are based on the Standard Bearing programme, please see 14-15. For systems which incorporate Track Rollers and/or Pinions, see 18-19.

CAD models are also available online.

Slides with Through Hole Fixing Bearings

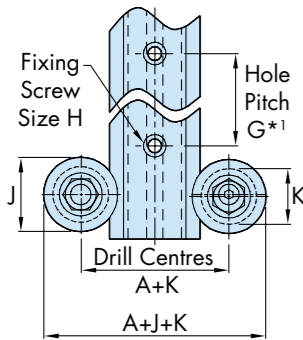

Slides with Blind Hole Fixing Bearings

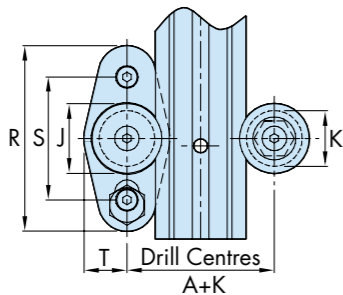

Slides with Cap Seals

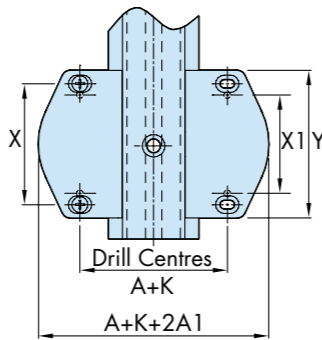

Slides with Lubricators

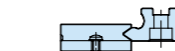
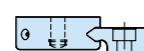
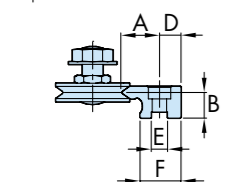
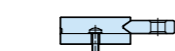
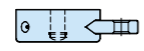
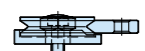
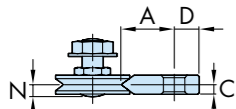
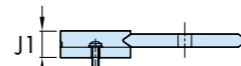
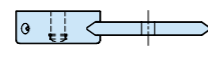
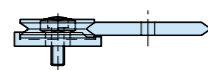
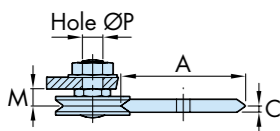
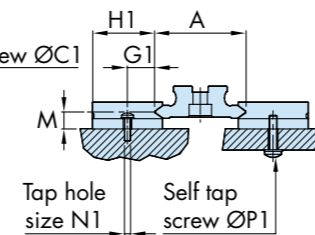
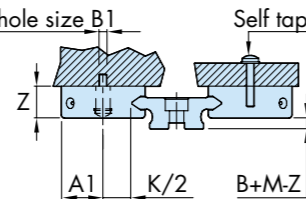
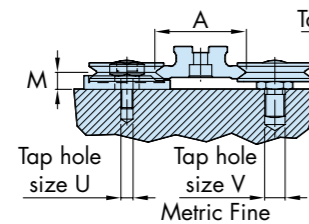
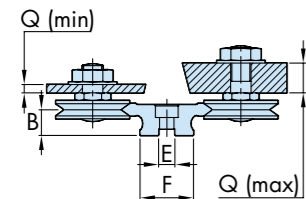
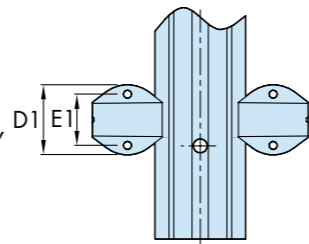

Part Number	A		B		C		D		E	F		G	H
	P1/P2	P3	P1	P2/P3	P1	P2/P3	P1/P2	P3		P1/P2	P3		
NMS 12...	12.37	13.25	6.2	6.4	-	-	-	-	4	8.5	8.9	45	M3
NV 20...	20.37	21.01	8	8.2	-	-	-	-	5	12	12.4	90	M4
NV 28...	28.37	29.01	8	8.2	-	-	-	-	6	20	20.4	90	M5
NS 25...	25.74	26.58	10	10.2	-	-	-	-	6	15	15.4	90	M5
NS 35...	35.74	36.38	10	10.2	-	-	-	-	8	25	25.4	90	M6
NS 50...	50.74	51.38	10	10.2	-	-	-	-	10	40	40.4	90	M6
NM 44...	44.74	45.58	12.5	12.7	-	-	-	-	8	26	26.4	90	M6
NM 60...	60.74	61.38	12.5	12.7	-	-	-	-	10	42	42.4	90	M8
NM 76...	76.74	77.38	12.5	12.7	-	-	-	-	12	58	58.4	90	M8
NL 76...	76.74	77.58	19.5	19.7	-	-	-	-	15	50	50.4	180	M12
NL 120...	120.74	121.38	19.5	19.7	-	-	-	-	45	94	94.4	180	M10

Part Number	A		B		C		D		E	F		G	H
	P1/P2	P3	P1	P2/P3	P1	P2/P3	P1/P2	P3		P1/P2	P3		
NMS E...	6.19	6.41	6.2	6.4	-	-	5	5.3	4	9.25	9.65	45	M3
NV E...	9.69	10.02	8	8.2	-	-	6.5	6.7	4	12	12.4	90	M4
NS E...	12.87	13.19	10	10.2	-	-	8.5	8.7	6	16	16.4	90	M5
NM E...	18.87	19.19	12.5	12.7	-	-	10.5	10.7	8	20	20.4	90	M6
NLE...	27.37	27.69	19.5	19.7	-	-	16	16.2	12	30	30.4	180	M10

MS 12...	12.55	13.13	-	-	1.52	1.60	-	-	-	-	-	30	M3
V 20...	20.37	21.01	-	-	2.14	2.21	-	-	-	-	-	90	M4
V 28...	28.37	29.01	-	-	2.14	2.21	-	-	-	-	-	90	M5
S 25...	25.81	26.58	-	-	2.39	2.47	-	-	-	-	-	90	M6
S 35...	35.81	36.58	-	-	2.39	2.47	-	-	-	-	-	90	M6
M 44...	44.81	45.58	-	-	3.14	3.21	-	-	-	-	-	90	M6
M 60...	60.81	61.58	-	-	3.14	3.21	-	-	-	-	-	90	M8
M 76...	76.81	77.38	-	-	3.14	3.21	-	-	-	-	-	90	M8
L 76...	76.81	77.58	-	-	4.56	4.72	-	-	-	-	-	90	M10
L 120...	120.81	121.58	-	-	4.56	4.72	-	-	-	-	-	180*3	M10*3

MS E...	6.87	7.1	-	-	1.52	1.60	4.5	4.7	-	-	-	45	M3
VE...	10.37	10.6	-	-	2.14	2.21	6	6.2	-	-	-	90	M4
SE...	12.96	13.3	-	-	2.39	2.47	6.5	6.7	-	-	-	90	M5
ME...	17.46	17.8	-	-	3.14	3.21	8	8.2	-	-	-	90	M6
LE...	22.46	22.8	-	-	4.56	4.72	10	10.2	-	-	-	90	M8

Part Number	J	K	M	N	P	Q (short axle)		Q (long axle)		R	S	T	U	V	W
						Min	Max	Min	Max						
...J195...	19.5	14.8	5.7	3.5	6	2.4	3.4	2.5	10	54	38	12.3	M4	M6x0.75	-
...J265...	26.5	20	6.8	4.5	8	2.2	3.8	4.9	13	72	50	16	M5	M8x1	-
...J360...	36	27.6	8.3	5.7	10	5.2	6.6	5.9	14.8	90.5	60	21	M6	M10x1.25	-
...J580...	58	46.1	14.3	8.5	14	5.7	8.2	7.9	20.4	133	89.5	31	M8	M14x1.5	-

Part Number	X	X1	Y	Z	A1	B1	C1	Use with Bearings
CW195	35	27.5	43	11.2	12	M2.5	3	...J195...
CW265	44	35	54	13	16	M3	3.5	...J265...
CW360	59	48	72	15.5	21	M4	4.5	...J360...
CW580	90	74	106	25	32	M5	6	...J580...

Part Number	D1	E1	F1	G1	H1	J1	K1	M1	N1	P1	Use with Bearings
LB195	19	13	-	7.5	17.5	8.7	-	-	M2.5	3	...J195...
LB265	25	18	-	9.6	23	10.3	-	-	M3	3.5	...J265...
LB360	34	25	-	13.4	31	12.9	-	-	M4	5	...J360...
LB580	50	38	-	19.9	49	21.9	-	-	M5	6	...J580...

Notes:

1. The NL120 and L120 Slides have two parallel rows of holes.



Systems with Track Rollers, Racks & Pinions

The section includes data on Single Edge Spacer Slides, Bearings, Track Rollers, Flat Tracks, Racks and Pinions to allow customers to calculate overall dimensions of a system and look up important dimensions, including drilling details.

It is possible to run a Wide Track Roller on the rear face of the Single Edge Spacer Slide, but this option is not shown, as the Narrow Track Roller usually fits better. The extra load capacity of the Wide Track Roller will not usually be a benefit when used with the Single Edge Spacer Slide, as the soft back face can be damaged if used beyond the load capacity of the Narrow Track Roller.

Single Edge Spacer Slide with 'V' Bearings and Track Rollers

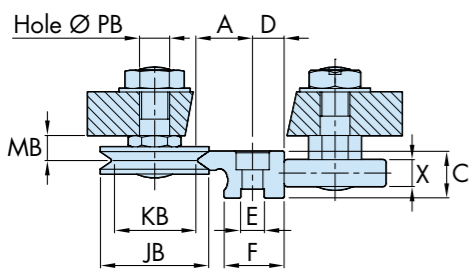
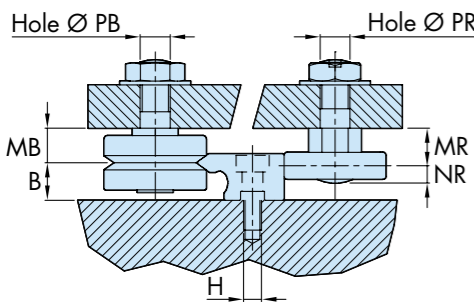
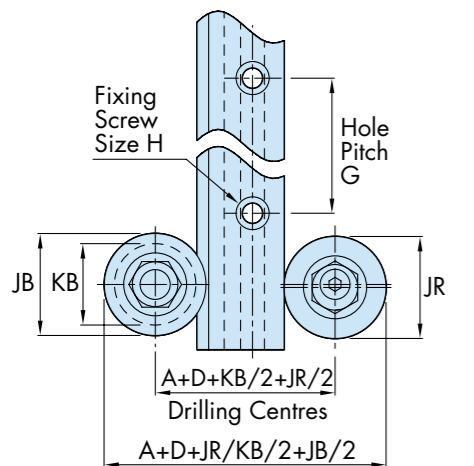

Single Edge Spacer Slide with 'V' Bearings and Pinions

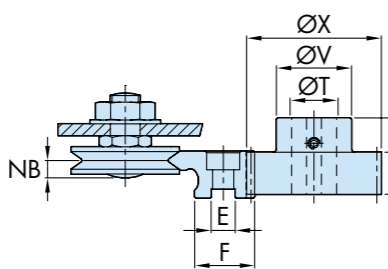
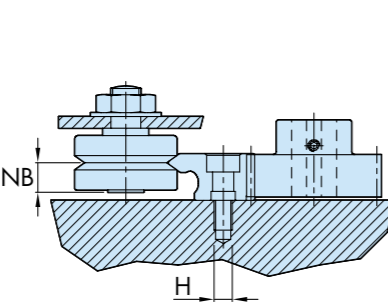
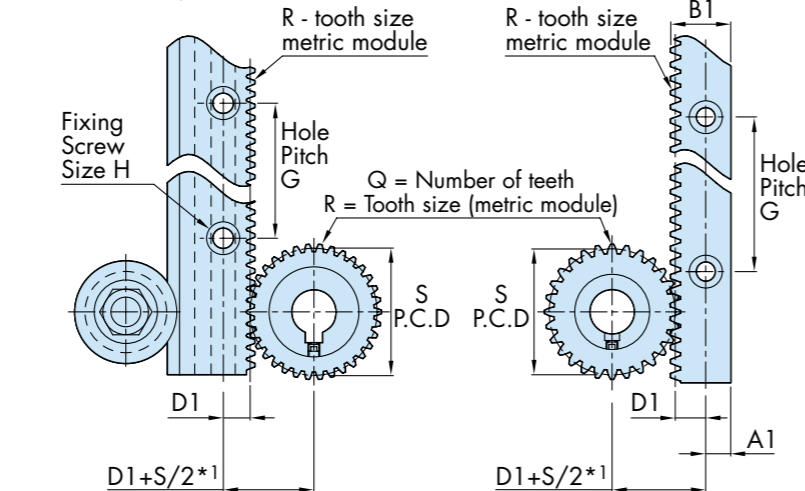

Racks with Pinions

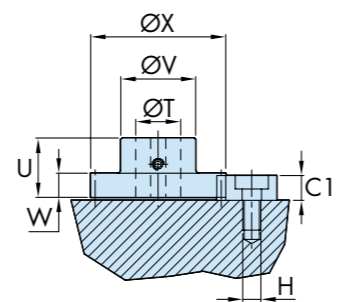
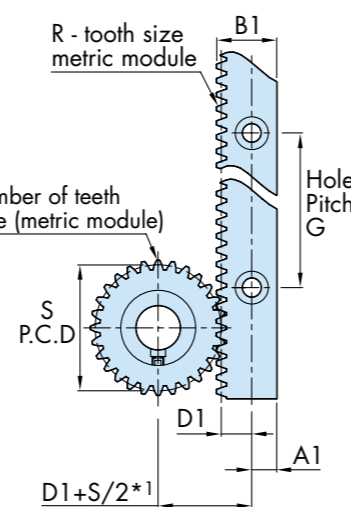

Flat Tracks with Through Hole Fixing Track Rollers

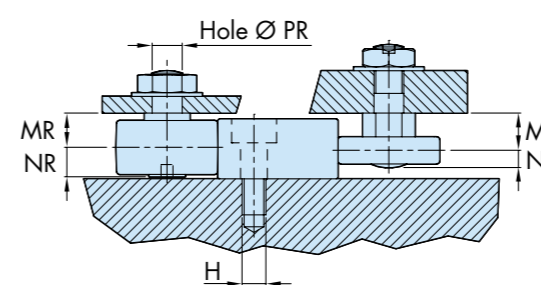
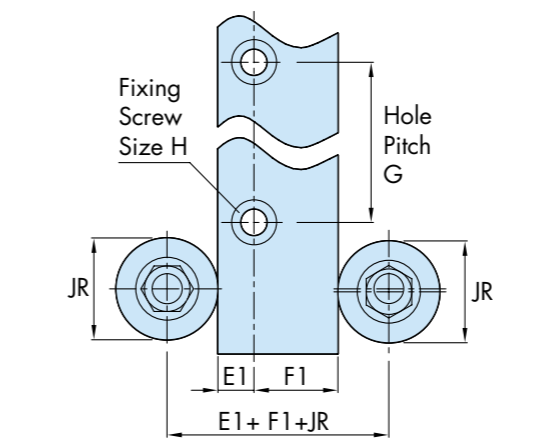

Flat Tracks with Blind Hole Fixing Track Rollers

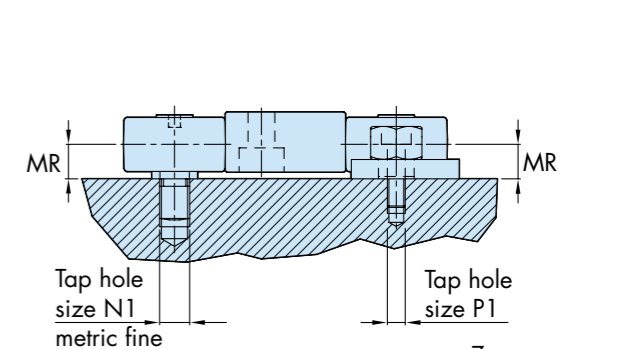
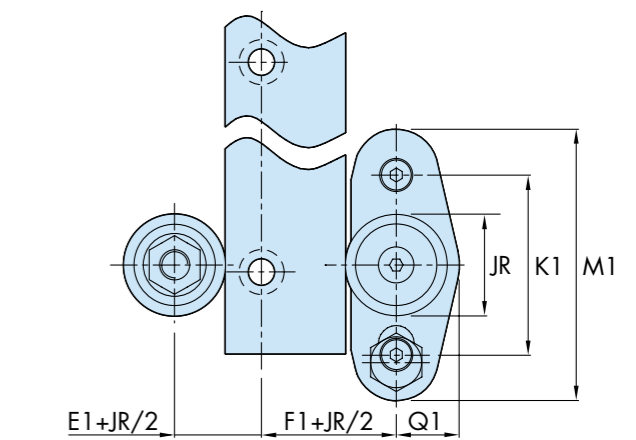

Part Number	A			B			C			D			D1*1	E	F		G	H
	P1/P2	P3	P1	P2/P3	P1	P2/P3	P1/P2	P3	P1/P2	P3	P1/P2	P3						
NMS E...	6.19	6.41	6.2	6.4	7.7	8.1	5	5.3	4.5	4	9.25	9.65	45	M3				
NV E...	9.69	10.02	8	8.2	10.0	10.43	6.5	6.7	5.8	4	12	12.4	90	M4				
NS E...	12.87	13.19	10	10.2	12.25	12.76	8.5	8.7	7.4	6	16	16.4	90	M5				
NM E...	18.87	19.19	12.5	12.7	15.5	15.98	10.5	10.7	9.25	8	20	20.4	90	M6				
NL E...	27.37	27.69	19.5	19.7	24.0	24.49	16	16.2	14.1	12	30	30.4	180	M10				

Part Number	A1	B1	C1	D1	G	H	S*1 Rack Module
R 10...	7.8	15.65	6.75	6.85	90	M5	1
R 15...	8.3	20	8.25	10.2	90	M6	1.5
R 20...	13.2	31.75	14	16.55	90	M10	2

Part Number	Q No of Teeth	R mod	S	T	U	V	X	W
P07 W9 T28...	28	0.7	19.6	5	17	16	21	9
P07 W5 T28...	28	0.7	19.6	5	13	16	21	5
P10 W11 T42...	42	1	42	15	23	30	44	11
P10 W7 T42...	42	1	42	15	18.5	30	44	7
P125 W14 T34...	34	1.25	42.5	15	25.5	30	45	14
P15 W8 T28...	28	1.5	42	15	19.8	30	45	8
P20 W20 T27...	27	2	54	20	35	40	58	20
P20 W13 T27...	27	2	54	20	25	40	58	13

Part Number	E1		F1		G	G1		H
	P1/P2B	P2A/P3	P1/P2B	P2A/P3		P1/P2A	P2B/P3	
FT 24 12	7.5	7.7	16.5	16.7	45	12	12.4	M5
FT 32 16	8.75	8.95	23.25	23.45	90	16	16.4	M6
FT 40 20	12	12.2	28	28.2	90	20	20.4	M8
FT 66 33	17	17.2	49	49.2	180	33	33.4	M12

All sizes of Track Roller (in both narrow and wide formats) have a 500 mm crown radius to avoid the problems which can occur if imperfect alignment concentrates the load on the edge of the Roller.

Any Track Roller can be used with any size of Flat Track or Single Edge Spacer Slide, subject to physical size constraints. Any Rack and Pinion combination can be used, subject to the tooth size matching, and other obvious size constraints.

The drawings below show only boss type Pinions. Pinions with integral shafts are also available.

Part Number	JB	KB	MB	NB	PB	Z (short axle)		Z (long axle)	
						Min	Max	Min	Max
...J13...	12.7	9.51	5.47	4.5	4	2.2	3	2.4	6.7
...J18...	18	14.00	6.75	5.6	6	2.4	3.4	2.5	10
...J25...	25	20.27	9.0	7.5	8	2.2	3.8	4.9	13
...J34...	34	27.13	11.5	9.7	10	5.2	6.6	5.9	14.8
...J54...	54	41.76	19.0	15.6	14	5.7	8.2	7.9	20.4
...J195...	19.5	14.8	5.7	3.5	6	2.4	3.4	2.5	10
...J265...	26.5	19.98	6.8	4.5	8	2.2	3.8	4.9	13
...J360...	36	27.57	8.3	5.7	10	5.2	6.6	5.9	14.8
...J580...	58	46.08	14.3	8.5	14	5.7	8.2	7.9	20.4

Part Number	JR	MR	NR	PR	Z (short axle)		Z (long axle)		M1	K1	Q1	P1	N1 Metric Fine
					Min	Max	Min	Max					
...R18...	18	6.75	5.6	6	2.4	3.4	2.5	10	54	38	12.25	M4	M6x0.75
...R25...	25	9.0	7.5	8	2.2	3.8	4.9	13	72	50	16	M5	M8x1
...R34...	34	11.5	9.7	10	5.2	6.6	5.9	14.8	90.5	60	21	M6	M10x1.25
...R54...	54	19.0	15.6	14	5.7	8.2	7.9	20.4	133	89.5	31	M8	M14x1.5
LRN18...	18	8	3.5	6	-	-	2.5	10					
LRN25...	25	10	4.5	8	-	-	4.9	13					
LRN34...	34	12.5	5.7	10	-	-	5.9	14.8					
LRN54...	54	21	8.5	14	-	-	7.9	20.4					

Note:

- The calculated position of the Pinion relative to the Rack gives an approximate location only. Customers should make provision for the Pinion to be adjusted relative to the Rack to ensure that the best running condition is achieved. The Hepco Gearbox and Drive Flange includes a facility for this type of adjustment.



GV3 Catalogue



GV3 Catalogue



GV3 Catalogue





GV3 Catalogue



GV3 Catalogue

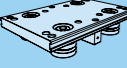

	Part Number	Mass (kg)	
Standard Carriages 	AU 12P1/P2 13 L50	0.07	
	AU 12P1/P2 13 L75	0.09	
	AU 12P1/P2 13 L100	0.11	
	Removable Carriages (See equivalent Standard Carriage for Removable Carriage mass.)	AU 12P3 13 L50	0.07
		AU 12P3 13 L75	0.09
		AU 12P3 13 L100	0.11
		AU 20 18 L65	0.21
		AU 20 18 L100	0.27
		AU 20 18 L140	0.34
		AU 28 18 L75	0.25
		AU 28 18 L125	0.36
		AU 28 18 L175	0.47
		AU 25 25 L80	0.41
		AU 25 25 L135	0.54
		AU 25 25 L180	0.66
		AU 35 25 L100	0.53
		AU 35 25 L150	0.7
		AU 35 25 L200	0.86
		AU 50 25 L110	0.67
		AU 50 25 L160	0.89
		AU 50 25 L220	1.2
		AU 44 34 L125	1.1
		AU 44 34 L180	1.4
		AU 44 34 L225	1.6
		AU 60 34 L150	1.5
		AU 60 34 L200	1.8
		AU 60 34 L280	2.3
		AU 76 34 L170	1.8
AU 76 34 L240		2.3	
AU 76 34 L340		3.1	
AU 76 54 L200		3.8	
AU 76 54 L300	4.8		
AU 76 54 L400	5.8		
AU 120 54 L240	5.5		
AU 120 54 L360	7.4		
AU 120 54 L480	9.3		

	Part Number	Mass (kg)
Slimline Carriages 	AU 20 195 L65	0.21
	AU 20 195 L100	0.27
	AU 20 195 L140	0.34
	AU 28 195 L75	0.25
	AU 28 195 L125	0.36
	AU 28 195 L175	0.47
	AU 25 265 L85	0.37
	AU 25 265 L135	0.51
	AU 25 265 L180	0.63
	AU 35 265 L100	0.5
	AU 35 265 L150	0.66
	AU 35 265 L200	0.83
	AU 50 265 L110	0.64
	AU 50 265 L160	0.86
	AU 50 265 L220	1.1
	AU 44 360 L125	0.95
	AU 44 360 L180	1.2
	AU 44 360 L225	1.4
	AU 60 360 L150	1.3
	AU 60 360 L200	1.6
	AU 60 360 L280	2.2
	AU 76 360 L170	1.7
	AU 76 360 L240	2.2
	AU 76 360 L340	3
	AU 76 580 L200	3.8
	AU 76 580 L300	3.5
	AU 76 580 L400	4.5
	AU 120 580 L240	5.3
AU 120 580 L360	7.2	
AU 120 580 L480	9.1	

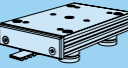
	Part Number	Mass (kg)
Belt Driven Carriages 	AUBD 35 25 L150	1.2
	AUBD 35 25 L230	1.7
	AUBD 50 25 L160	1.6
	AUBD 50 25 L240	2.3
	AUBD 44 34 L200	2
	AUBD 44 34 L280	2.8
	AUBD 60 34 L224	3.4
	AUBD 60 34 L304	4.3
	AUBD 76 34 L244	4.1
	AUBD 76 34 L344	5.6

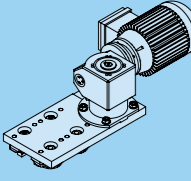
	Part Number	Mass (kg)
Rack Driven Carriages 	AURD 44 34 L300 DRCS	3.1
	AURD 44 34 L420 DRCS	3.9
	AURD 60 34 L320 DRCS	3.4
	AURD 60 34 L440 DRCS	4.2
	AURD 76 34 L320 DRCS	3.5
	AURD 76 54 L360 DRCS	6.2
	AURD 76 54 L500 DRCS	7.7
	AURD 120 54 L380 DRCS	7.4
	AURD 120 54 L540 DRCS	9.4

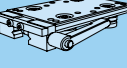
	Part Number	Mass (kg)
Carriage Locking Device 	BK2525	1.9
	BK3525	0.2
	BK4434	0.3
	BK5025	0.4
	BK6034	0.6
	BK7634	0.8
	BK7654	1.5
BK12054	1.5	

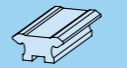
	Part Number	Mass (kg/m)
Double Edge Spacer Slides (Slide Only) 	NMS 12...	0.5
	NV 20...	1.0
	NV 28...	1.6
	NS 25...	1.5
	NS 35...	2.3
	NS 50...	3.2
	NM 44...	3.5
	NM 60...	5.5
	NM 76...	7.0
	NL 76...	10
	NL 120...	15

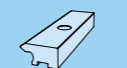
	Part Number	Mass (kg/m)
Single Edge Spacer Slides 	NMS E...	0.55
	NV E...	1.0
	NS E...	1.6
	NM E...	2.6
	NL E...	6.0

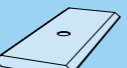
	Part Number	Mass (kg/m)
Double Edge Flat Slides 	MS 12...	0.23
	V 20...	0.6
	V 28...	0.9
	S 25...	0.8
	S 35...	1.3
	S 50...	1.7
	M 44...	1.9
	M 60...	2.7
	M 76...	3.4
	L 76...	5.0
	L 120...	8.5

	Part Number	Mass (kg/m)
Flat Tracks 	FT 24 12	2.3
	FT 32 16	4.0
	FT 40 20	6.3
	FT 66 33	17

	Part Number	Mass (kg/m)
Racks 	R 07...	0.37
	R 10...	0.77
	R 15...	1.2
	R 20...	3.3

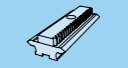
	Part Number	Mass (kg/m)
Double Edge Spacer Slides (With Rack) 	NV 20...R...	1.4
	NV 28...R...	2.0
	NS 25...R...	2.3
	NS 35...R...	3.0
	NS 50...R...	4.0
	NM 44...R...	4.7
	NM 60...R...	5.7
	NM 76...R...	8.2
	NL 76...R...	13
NL 120...R...	18	

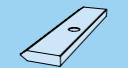
	Part Number	Mass (kg/m)
Single Edge Flat Slides 	MS E...	0.22
	V E...	0.5
	S E...	0.7
	M E...	1.2
	L E...	2.2

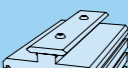
	Part Number	Mass (kg/m)
Slide Beams 	SB S 35...	6.0
	SB S 35...L...	4.3
	SB S 50...	6.5
	SB S 50...L...	4.7
	SB M 44...	10
	SB M 60...	11
SB M 76...	11.5	





	Part Number	Mass (kg)
Standard Bearings  & Vacuum Bearings (See equivalent Standard Bearing for Vacuum Bearing mass.)	SJ 13...	0.008
	SJ 18...	0.019
	SJ 25...	0.048
	SJ 34...	0.115
	SJ 54...	0.415
	LJ 13...	0.008
	LJ 18...	0.020
	LJ 25...	0.051
	LJ 34...	0.120
	LJ 54...	0.425
	BHJ 13 C...	0.007
	BHJ 18 C...	0.018
	BHJ 25 C...	0.043
	BHJ 34 C...	0.105
	BHJ 54 C...	0.390
	BHJ 13 E...	0.027
	BHJ 18 E...	0.045
	BHJ 25 E...	0.105
BHJ 34 E...	0.235	
BHJ 54 E...	0.800	

	Part Number	Mass (kg)
Slimline Bearings 	GSJ 195...	0.014
	GSJ 265...	0.028
	GSJ 360...	0.065
	GSJ 580...	0.280
	GLJ 195...	0.016
	GLJ 265...	0.030
	GLJ 360...	0.070
	GLJ 580...	0.290
	GBHJ 195 C...	0.013
	GBHJ 265 C...	0.023
	GBHJ 360 C...	0.055
	GBHJ 580 C...	0.255
	GBHJ 195 E...	0.040
	GBHJ 265 E...	0.085
	GBHJ 360 E...	0.185
	GBHJ 580 E...	0.660



	Part Number	Mass (kg)
Axial Stiffness Bearings 	...SUJ 20...	0.018
	...SUJ 25...	0.042
	...SUJ 34...	0.097
	...SUJ 40...	0.172
	...LUJ 20...	0.019
	...LUJ 25...	0.046
	...LUJ 34...	0.102
	...LUJ 40...	0.181

	Part Number	Mass (kg)
Wide Track Rollers 	SR 18...	0.020
	SR 25...	0.050
	SR 34...	0.120
	SR 54...	0.440
	LR 18...	0.021
	LR 25...	0.055
	LR 34...	0.125
	LR 54...	0.450
	BHR 18 C...	0.019
	BHR 25 C...	0.045
	BHR 34 C...	0.110
	BHR 54 C...	0.415
	BHR 18 E...	0.045
	BHR 25 E...	0.105
BHR 34 E...	0.235	
BHR 54 E...	0.800	

	Part Number	Mass (kg)
Narrow Track Rollers 	LRN 18...	0.016
	LRN 25...	0.040
	LRN 34...	0.085
	LRN 54...	0.310

	Part Number	Mass (kg)
Vacuum Track Rollers 	VAC LRN 25...	0.04
	VAC LRN 34...	0.085
	VAC LRN 54...	0.310

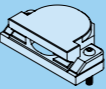
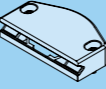
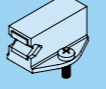
	Part Number	Mass (kg)
Floating Bearings 	SFJ 25...	0.058
	SFJ 34...	0.130
	SFJ 54...	0.492
	LFJ 25...	0.060
	LFJ 34...	0.135
	LFJ 54...	0.505

	Part Number	Mass (kg)
Lubrication Device    	CS 18	0.006
	CS 25	0.013
	CS 34	0.028
	CS 54	0.078
	CW 195	0.006
	CW 265	0.010
	CW 360	0.020
	CW 580	0.055
	LB 12	0.002
	LB 20	0.003
	LB 25	0.006
	LB 44	0.016
	LB 76	0.044
	LB 195	0.002
	LB 265	0.004
	LB 360	0.008
LB 580	0.030	

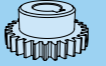
	Part Number	Mass (kg)
Pinions (Boss type) 	P05 W7 T28...	0.011
	P07 W9 T28	0.031
	P07 W5 T28...	0.022
	P10 W11 T42...	0.160
	P10 W7 T42...	0.120
	P125 W14 T34...	0.20
	P15 W8 T28...	0.125
	P20 W20 T27...	0.430
	P20 W13 T27...	0.300

	Part Number	Mass (kg)
Flange Clamps 	SFC 25	0.120
	SFC 35	0.240
	SFC 50	0.260
	SFC 44	0.220
	SFC 60	0.370
	SFC M76	0.530
	SFC 76	0.500
	SFC 120	1.050
	LFC 25	0.405
	LFC 35	0.740
	LFC 50	0.770
	LFC 44	0.630
	LFC 60	1.150
LFC M76	1.780	
LFC 76	1.430	
LFC 120	2.750	





Hepco Removable Carriages are available to suit all sizes of Double Edge Slides, in all grades of precision.

Carriage Plates are precision machined from aluminium alloy and are supplied clear anodised.

Carriages may be specified as **Assembled Units (AU Type)**, either factory set to the chosen Slide, or without Slide for self-adjustment.

The key feature of Removable Carriages is the incorporation of Double Eccentric Bearings. By slackening the Bearing axle fixing nuts and rotating the eccentric using the adjusting spanner, the Carriage can be disengaged from the Slide (see GV3 catalogue). This can be a considerable advantage over Standard and Slimline Carriages, which must either be run off the end of the Slide, or be disassembled to allow removal.

The following types of Bearing and lubrication device may be specified (refer also to availability table below right).

The Twin Bearing type which is the default choice, comprises two individual Bearings on a common axle. This offers some compliance, with smoother running, easy adjustment and greater tolerance of misalignment.

The Double Row Bearing type (DR) incorporates a one piece Bearing with two ball tracks. This offers higher load capacity, especially in the radial direction and is less susceptible to entrapment of debris.

The Nitrile Sealed Bearing option (NS) provides a higher degree of sealing against ingress of water or debris than does the default metal shielded type. A small increase in friction may result.

The Controlled Height Bearing option (CHK) minimises variation between Bearings in respect of the important 'K' dimension. This is desirable in high precision applications.

The Lubricator option (LB) applies oil to the 'V' contact surfaces by means of lightly sprung felt pads which are charged with oil to give long intervals between re-lubrication. The Lubricator option is useful where the advantages of increased load and life are required but with lower friction compared to the Cap Seal.

Lubricators are fixed with screws through the Carriage, so that they can be detached easily in the event of Carriage removal from the Slide.

See Application Example on 10 of the GV3 catalogue



Example: Short Removable Carriage with Lubricators on a Flat Slide

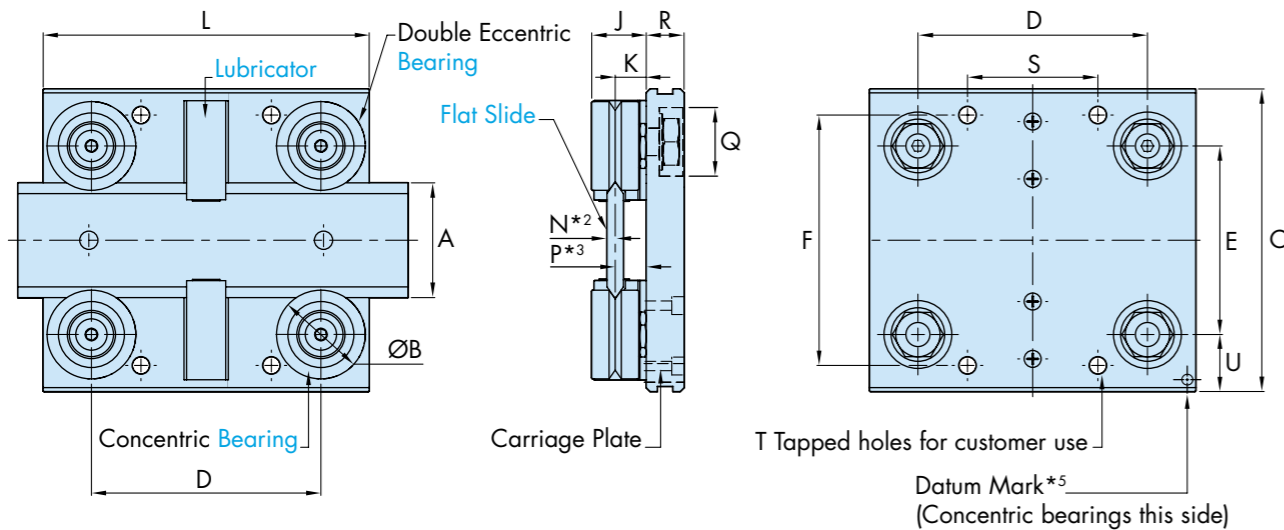

Example: Medium Removable Carriage on a Spacer Slide

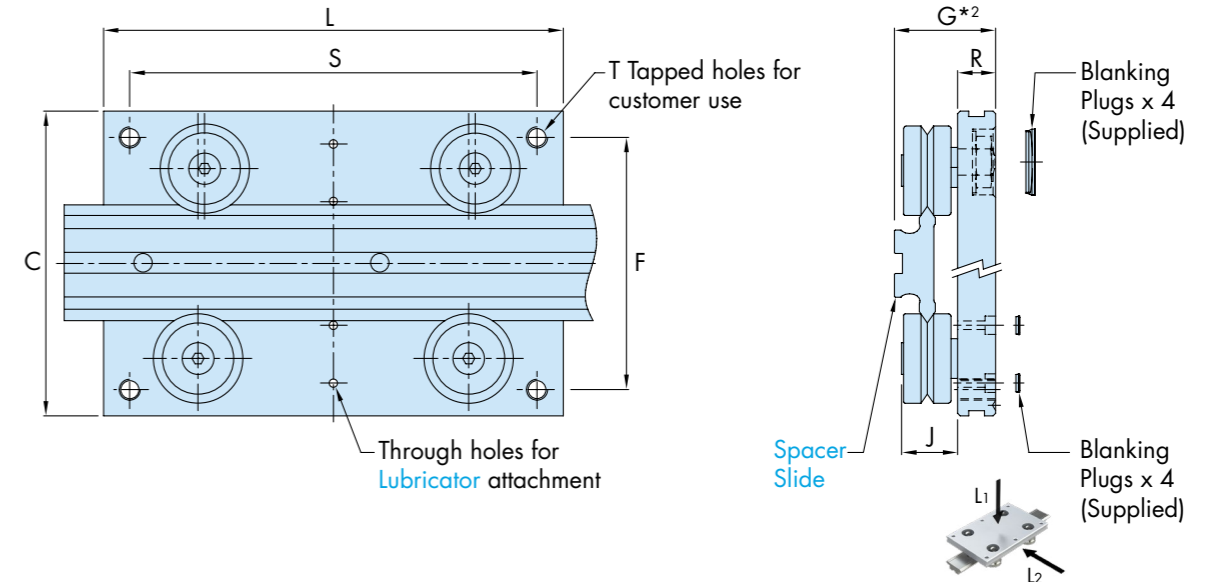

Part Number	Use With		A	ØB	C	E	F	G*2		J	K	N*2		P*2,3	Q	R	Short Carriage			Medium Carriage			Long Carriage			T	U	Max Load Capacity (N)*1				
	MS	NMS						P1	P2 & P3			Ø x depth	L				D	S	L	D	S	L	D	S	DR L1			DR L2	Twin L1	Twin L2		
	~																															
AU 12 13 R ...	NMS 12	MS 12	12	13	40	23.3	30	19	19.2	10.1	5.46	1.49	1.6	3.8	12.5 x 4.8	7.34		50	35	17	75	60	25	100	85	50	4xM4	9	-	-	240	240
AU 20 18 R ...	NV 20	V 20	20	18	64	35.9	50	24.75	24.95	12.4	6.75	2.1	2.2	4.5	16 x 7	10		65	43	20	100	55	88	140	95	124	4xM5	14.7	760	1200	500	400
AU 28 18 R ...	NV 28	V 28	28		72	43.9	58	25.75	25.95								5.5	16 x 8	11		75	52	25	125	80	110						
AU 25 25 R ...	NS 25	S 25	25	25	80	48.3	65	30.5	30.7	16.6	9	2.36	2.5	6.5	22 x 8.4	11.5		80	51	24	135	74	120	180	120	164	4xM6	19.2	1600	3000	1280	1200
AU 35 25 R ...	NS 35	S 35	35		95	58.3	80	31.5	31.7								2.34	22 x 9.4	12.5		100	70	40	150	90	130						
AU 50 25 R ...	NS 50	S 50	50		112	73.3	95	33	33.2						22 x 10.9	14		110	80	50	160	100	140	220	160	200						
AU 44 34 R ...	NM 44	M 44	44	34	116	74.8	96	38.5	38.7	21.3	11.5	3.08	3.2	8.3	25 x 8.7	14.5		125	88	50	180	103	160	225	153	206	4xM8	21.9	3600	6000	3200	2800
AU 60 34 R ...	NM 60	M 60	60		135	90.8	115	41	41.2								3.05	25 x 11	17		150	110	60	200	125	180						
AU 76 34 R ...	NM 76	M 76	76		150	106.8	130	42	42.2						25 x 12.5	18		170	130	80	240	165	220	340	265	320						
AU 76 54 R ...	NL 76	L 76	76	54	185	123.0	160	58.5	58.7	34.7	19	4.56	4.7	14.3	32 x 13.5	20		200	140	90	300	198	270	400	298	370	4xM10	33	10000	10000	7200	6400
AU 120 54 R ...	NL 120	L 120	120		240	167.0	210	62.5	62.7								32 x 17.5	24				240	180	120	360	258						

Notes:

- Maximum loads quoted assume lubrication at the interface of Bearings and Slide. This can best be achieved by using Cap Seals or Lubricators. It is strongly recommended that load and life are determined using the methods shown in the Load/Life Calculations section of the GV3 catalogue. The Bearing static and dynamic load capacities (C & Co) often quoted by manufacturers are not the best basis for practical life calculations. C & Co figures are included on the Bearing pages for comparison.
- Some dimensions will vary by the amount of the grinding allowance according to which grade of Slide is selected. All Carriages are compatible with all grades of Slide.
- Carriage size AU 28 18 R incorporates a recess in the underside for fixing screw clearance when used with size V28 Flat Slide. The P dimension in the table includes this recess.
- Controlled Height (CHK) Bearings are available in five bands, grouped in steps of 0.020mm from B1-0.050mm to B1+0.050mm, in respect of the B1 dimension given in the Standard Bearings section of the main GV3 catalogue. They are supplied in sets of up to 50 parts as standard, with larger sets on request. Customers requiring CHK Bearings within the same tolerance band, in respect of a number of Carriages, should state this on their order.
- The datum mark identifies the reference edge used in manufacture. The concentric Bearings are always mounted on this side.

Ordering Details

2 x AU4434 L180 R (LB) (DR) (NS) (CHK) + Slide Part Number

Number of Carriages set to specified Slide
AU... = Part Number
L = Carriage Length = 180mm
R = Removable Type Carriage
LB = Lubricators
 Leave blank if not required.

Leave blank if Slide not required and Carriage will be supplied in a loose condition for self-adjustment
CHK = Controlled Height Bearings*4
 Leave blank for standard tolerance
NS = Nitrile Sealed Bearings
 Leave blank for metal shielded
DR = Double Row Bearings
 Leave blank for Twin Bearings

Availability of Carriage Options

Part Number	Twin Bearings	Double Row	Metal Shields	Nitrile Shields	Lubricators	Controlled Height
AU 12 13 R...	✓	✗	✗	✓	✓	✓
AU 20 18 R...	✓	✓	✗	✓	✓	✓
AU 28 18 R...	✓	✓	✗	✓	✓	✓
Larger sizes	✓	✓	✓	✓	✓	✓

HepcoMotion Racks, Shaft Type Pinions, Drive Flanges and Gearboxes or AC Geared Motors can be used to construct a range of different Rack Driven system configurations.

Hepco Rack Driven Carriages run on Double Edge Spacer Slides with a precision machined Rack.

Two examples of other configurations are shown below:

System with opposing Single Edge Spacer Slides

One Single Edge Spacer Slide has a rack cut into the back face, engaged with a Pinion.

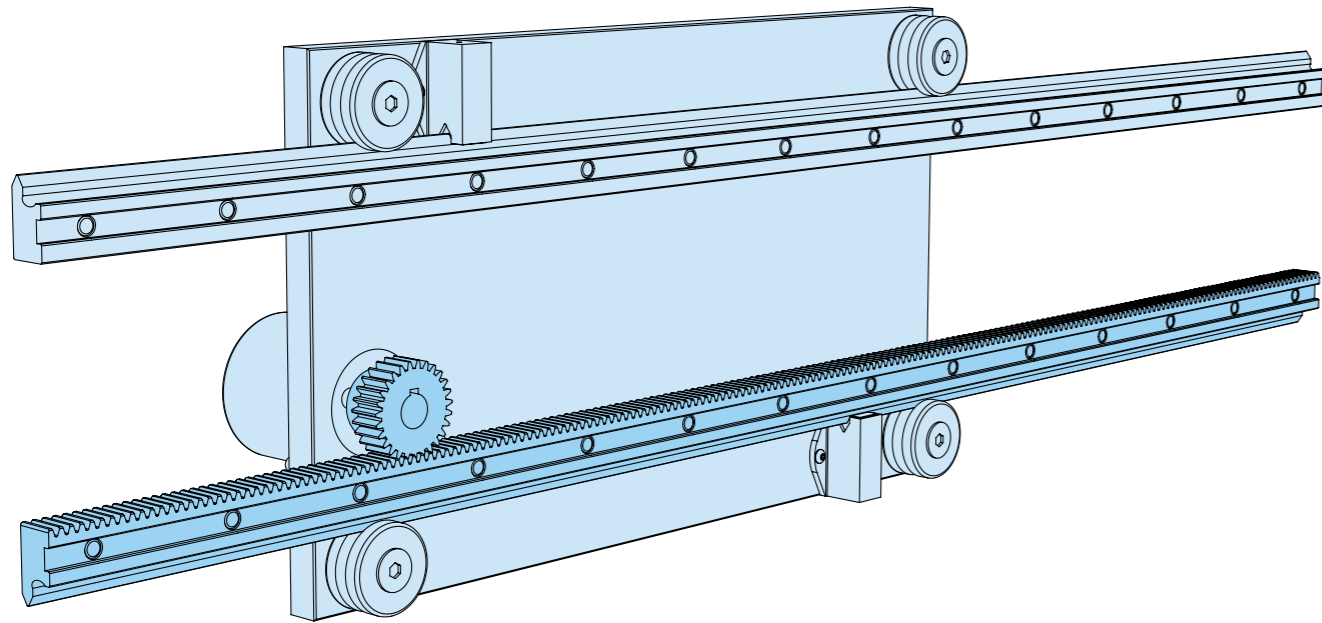

System with driven Rack

A Hepco Drive Flange and hollow shaft motor driven worm gearbox are mounted to a fixed plate.

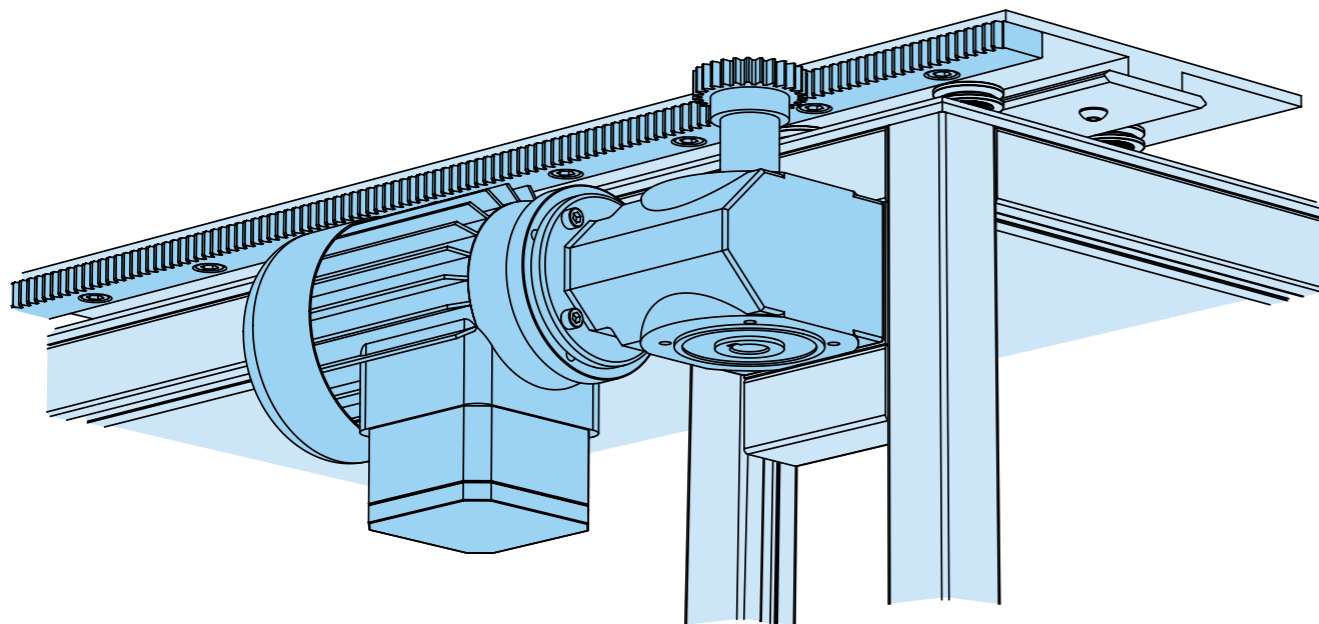

Our Technical Department will be pleased to assist with all aspects of specification and ordering.

Shaft Type Pinions have an extended shaft with keyed diameter and are compatible with Rack Driven Carriages, which incorporate the Hepco Drive Flange and hollow shaft motor driven worm Gearbox.

All Shaft Type Pinions have metric module hardened and ground teeth at a 20° pressure angle, conforming to ISO 1328 grade 6.

The Pinions are supplied with the key, retaining washer and screw necessary to connect to the worm Gearbox.

For best performance, the teeth of the Rack and Pinion should be lubricated with No.2 lithium soap-based grease.

See Application Examples on 13, 15 & 17 of the GV3 catalogue

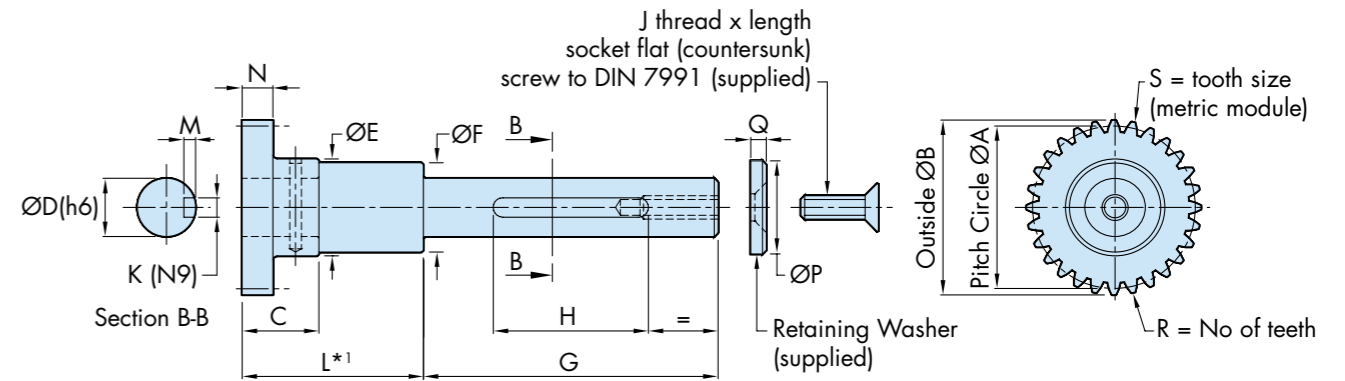

Part Number	A	B	C	D	E	F	G	H	J	K	L*1	M	N	P	Q	R	S
										Thread x Length							
P10 W11 T42 S ...	42	44	23	15	30	23	76	40	M6x16	5	to order	3	11	24	4	42	1
P125 W14 T34 S ...	42.5	45	25.5	20	30	30	81	50	M8x20	6	to order	3.5	14	32	5	34	1.25
P15 W8 T28 S ...	42	45	19.8	15	30	23	76	40	M6x16	5	57.4	3	8	24	4	28	1.5
P20 W20 T27 S ...	54	58	35	20	40	30	81	50	M8x20	6	to order	3.5	20	32	5	27	2
P20 W13 T27 S ...	54	58	25	20	40	30	81	50	M8x20	6	64.4	3.5	13	32	5	27	2

Part Number	For Use With			
P10 W11 T42 S ...	-	NSE...R	-	WG3...
P125 W14 T34 S ...	-	NME...R	-	WG4...
P15 W8 T28 S ...	R15...	-	NM...R	WG3...
P20 W20 T27 S ...	-	NLE...R	-	WG4...
P20 W13 T27 S ...	R20...	-	NL...R	WG4...

Ordering Details

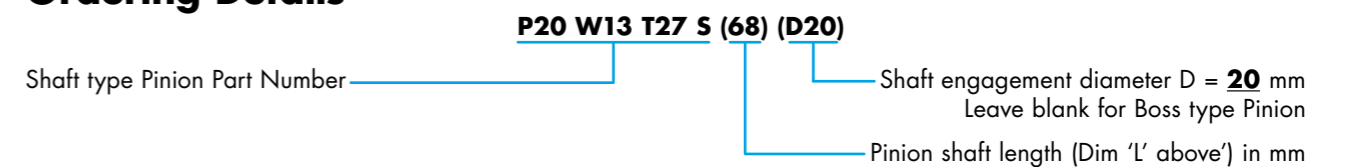

Notes:

- The length of the Pinion shaft will depend on the exact design. Shaft Type Pinions are made to length from part machined stock, to ensure rapid delivery and economy. The lengths shown for the P15W8T28 & P20W13T27 are those used in the Hepco Rack Driven Carriage. Other lengths are available as required.

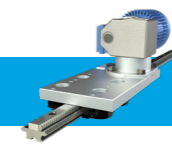

The information presented in this section details the options available when specifying a non-standard GV3 Rack Driven Carriage. For standard specifications, please refer to the GV3 catalogue.

Rack Driven Carriages include the Hepco Worm Gearbox, Drive Flange and Shaft Pinion of suitable ratio. The Gearbox may be supplied coupled with an integral Hepco AC Motor, which is the most economical means of producing point to point linear motion, and which may be controlled via the Hepco AC Speed Controller. The Gearbox can also be supplied with an adaptor flange and input shaft coupling tailored to suit other makes or types of motors including steppers and servos, which benefit from the low backlash of the Hepco Gearbox.

Part Number	Use With	A	B	F	F1		G	G1	G2	H	J	K	N	P	P1	Q	Q1	R	S		T	U		V	V1	W	W1	W2	W3	W4	Z	Rack Drive Force/N ⁵
					Standard	Removable													P1	P2 & P3		P1 & P2	P3									
					~																											
AU RD 44 34...	NM44...R	44	133	38.2	72.3	74.8	28.8	22	97.8	56	74.1	14	18	22.5	70	21.3	34	17	42	42.25	8	26	26.5	1.5	42	35	71	5.4	7.5	25	118	400
AU RD 60 34...	NM60...R	60	144	29.7	88.3	90.8	20.3	22	105.3	56	74.1	41	18	22.5	70	21.3	34	17	42	42.25	10	42	42.5	1.5	42	35	71	5.4	7.5	25	118	400
AU RD 76 34...	NM76...R	76	154	21.7	104.3	106.8	12.3	22	113.3	56	74.1	41	18	22.5	70	21.3	34	17	42	42.25	12	58	58.5	1.5	42	35	71	5.4	7.5	25	118	400
AU RD 76 54...	NL76...R	76	193	41.2	119.1	123	27.2	33	141.2	80	100.6	57	20	36.5	98	34.7	54	25	58.5	58.75	15	50	50.5	2	54	34.5	72.5	6.5	9.5	32	147	700
AU RD 120 54...	NL120...R	120	240	38.5	163.1	167	24.5	33	182.5	80	119.8	111.3	20	36.5	98	34.7	54	25	58.5	58.75	45	94	94.5	2	54	34.5	72.5	6.5	9.5	32	147	700

Please see other table for dimensions C, D, E & L.

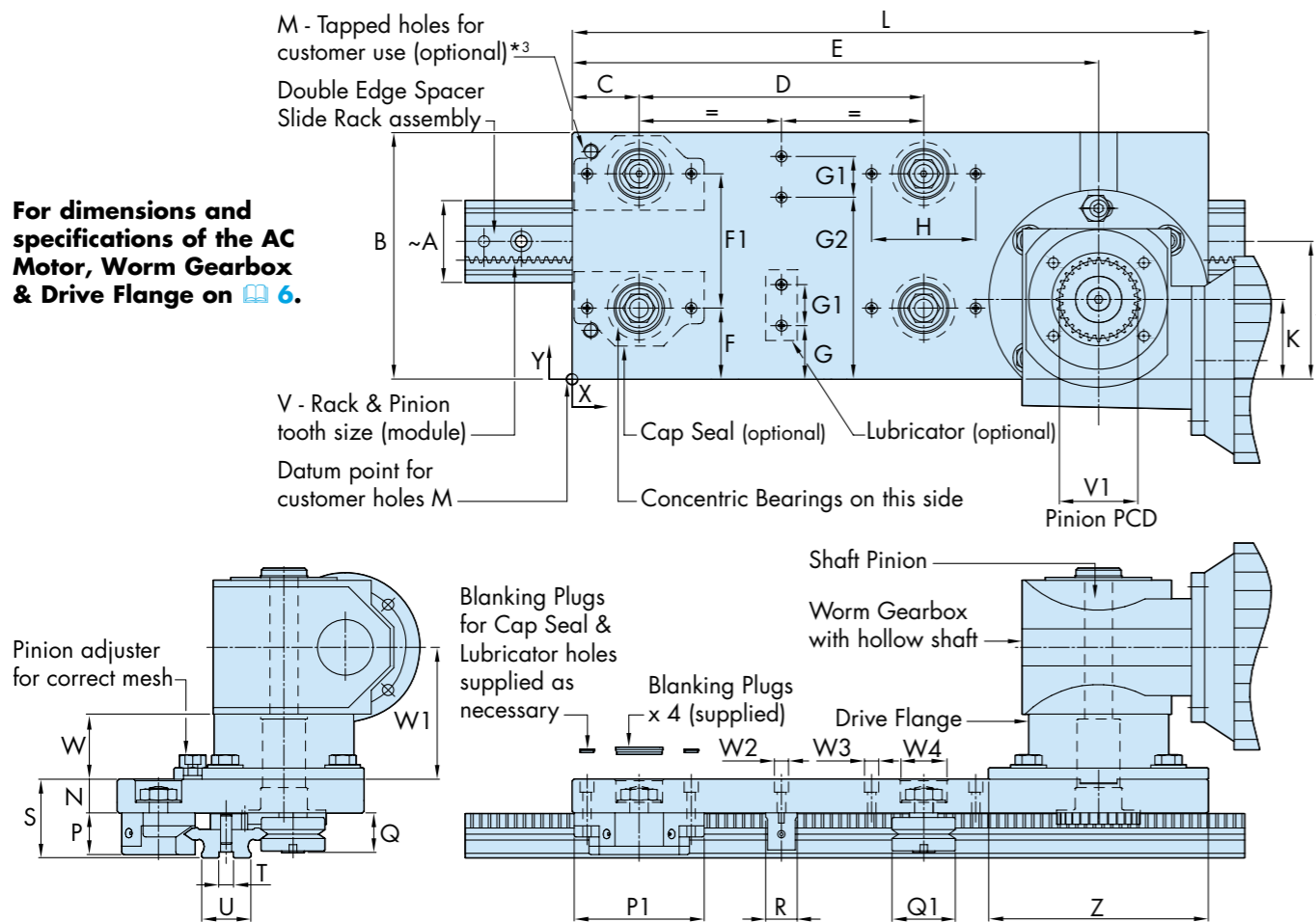

Notes:

- The maximum load capacities quoted on the Standard and Removable Carriage pages of the main GV3 catalogue, assume lubrication at the interface of Bearings and Slide. This can best be achieved by using Cap Seals or Lubricators. It is strongly recommended that load and life are determined using methods shown in the Calculations section of the GV3 catalogue.
- Controlled Height (CHK) Bearings are usually selected from stock, quantities available may therefore be restricted. Please refer to 38 of this guide. Customers requiring CHK Bearings within the same tolerance band in respect of a number of Carriages should state this on their order.
- Any number and size of tapped mounting holes 'M' can be provided in any available position. These may be specified in the ordering details after the designation M by stating the co-ordinates X & Y relative to the datum point, followed by the tapped hole size. **Example:** M - X10Y25M6 - x=10 mm, y=25 mm, hole size = M6. Care should be taken to avoid any hole position that bridges the contact area between Cap Seal and Carriage Plate as this will allow grease to escape.
- The removable option is not available in conjunction with Cap Seals.
- The quoted rack drive force is determined by the Rack and Pinion size, gearbox Bearings and gears, and the duty. See 8-9 for full details.

Carriages may be specified with the Removable Option, enabling the Carriage to be disengaged from the Slide at any position along its length. Bespoke Carriages are available on short delivery for customers wishing to use their own motor, gearbox and Pinion.

Rack Driven Carriages are normally supplied as Assembled Units (AU type), which are factory assembled and set to the Slide. More specific information regarding the options for Bearings, Lubrication Devices and load capacities are provided in the GV3 catalogue*. For details of linear drive performance, please see 8-9.

See Application Example on 13 of the GV3 catalogue

Specifying the Format and Size of the Carriage

Three styles of Carriage are available with motor mounting positions as shown in the diagram below. The style and size are specified by selecting the required values for dimensions C, D, E, & L in the table below the diagram. Any values for these dimensions may be chosen subject to the recommended limitations in the table.

If Lubricators are specified with 'style 2' Carriage, these will be offset to one another as indicated in the diagram.

The motor and gearbox can be mounted in any one of 8 orientations. Please see 6.

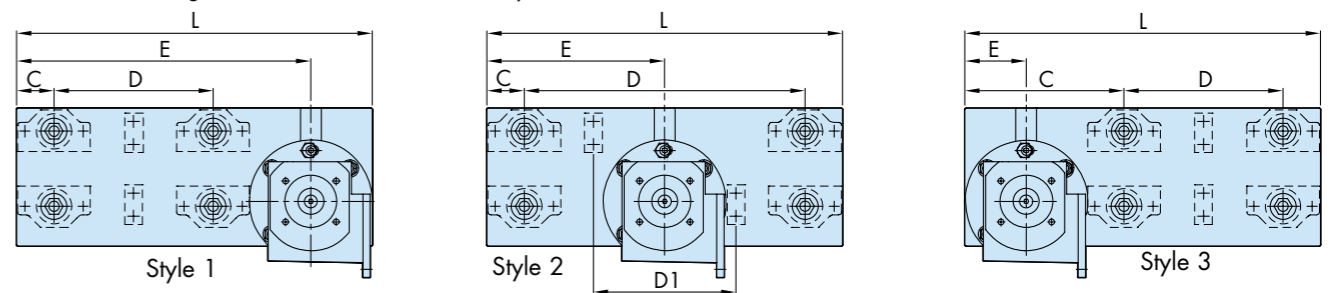

Carriage Style	Part Number	Minimum Recommended Values								
		With Cap Seals				With Lubricators				
		C	D	E	L	C	D	D1	E	L
Style 1	AU RD...34...	36	F1	C+D+92*	E+60	18	F1	-	C+D+73*	E+60
	AU RD...54...	51	F1	C+D+119*	E+75	28	F1	-	C+D+91*	E+75
Style 2	AU RD...34...	36	182*	C+92*	C+D+36	18	177*	124	C+89*	C+D+18
	AU RD...54...	51	237*	C+119*	C+D+51	28	235*	154	C+118*	C+D+28
Style 3	AU RD...34...	E+92*	F1	59	C+D+36	E+73*	F1	-	59	C+D+18
	AU RD...54...	E+119*	F1	73.5	C+D+51	E+91*	F1	-	73.5	C+D+28

Figures marked * are the minimums which can be achieved without the flange covering the Bearing stud counterbore or the Cap Seal or Lubricator fixings. Smaller values of these dimensions can be achieved if overlap is acceptable to the customer. When specifying such reduced dimensions, the customer should ensure that the Pinion does not interfere with either Bearings, Cap Seals or Lubricators.

Ordering Details

AURD4434 L288 C36 D100 E228 (M) (R) (DR) (NS) (CHK) (CS)

Part Number _____
 AU... = Assembled Carriage
 Carriage Length L = 288 mm
 Dimension C = 36 mm
 Dimension D = 100 mm
 Dimension E = 228 mm
 M = Customer mounting holes*3
 Leave blank if not required
 R = Removable Carriage Option*4
 Leave blank if not required

Lubrication Options:
CS = Cap Seals or **LB** = Lubricators
 Leave blank if not required
CHK = Controlled Height Bearings*2
 Leave blank if not required
NS = Nitrile Sealed Bearings
 Leave blank if not required
DR = Double Row Bearings
 Leave blank if not required

AC Motor/Worm Gearbox 6-7 - Please state part number as the second line of your order.

Double Edge Spacer Slide Rack Assembly - Please state part number as the third line of your order.

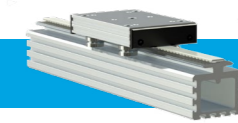

HepcoMotion Belt Driven Carriages are available to suit ten sizes of Double Edge Slide in all grades of precision. They have all of the benefits of the Standard Carriages along with many additional features:

Carriages may be specified with the **Removable Option**, which is the key feature of the **Removable Carriage**. This allows the Carriage to be disengaged from the Slide at any position along its length, without the need for complete disassembly.

Each Belt Driven Carriage incorporates a base plate and a **Removable Top Plate** which can simply be unscrewed and reworked as required. Tapped holes are provided in convenient positions to enable components to be attached.

Belt Driven Carriages are normally supplied as **Assembled Units (AU type)** which are factory assembled and set to the Slide. Information regarding the options for Bearings, Lubrication Devices and load capacities is given on the page for Standard Carriages*1 in the GV3 catalogue.

Example: Short Carriage with Cap Seals on a Spacer Slide

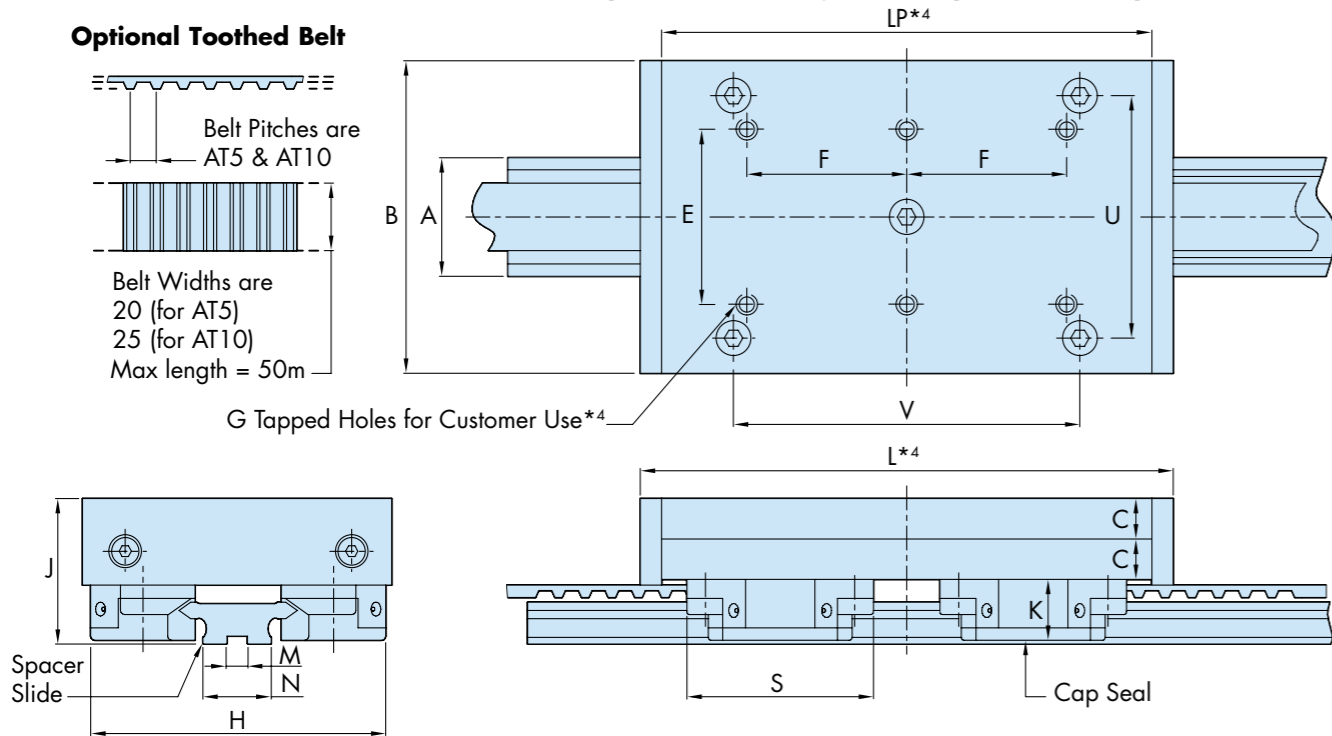

Part Number	Use With		Bearing Ø	A	B	C	D*4	E	F*4	G*4		H	J*2		K		
	NS35	S35								No of Holes x Thread			P1	P2 & P3			
AU BD 35 25...	NS35	S35	25	35	90	13	70	150	48	50	100	4xM6	6xM6	88	45	45.2	18
AU BD 50 25...	NS50	S50	25	50	112	14	82	162	60	50	90	4xM6	6xM6	103	47	47.2	18
AU BD 44 34...	NM44	M44	34	44	116	15	95	168	65	60	90	6xM8	6xM8	114	54	54.2	22.5
AU BD 60 34...	NM60	M60	34	60	135	17	119	199	75	75	115	6xM8	6xM8	130	58	58.2	22.5
AU BD 76 34...	NM76	M76	34	76	150	18	139	239	100	80	130	6xM8	6xM8	146	60	60.2	22.5

Part Number	Part Number	Pulleys							Belt Part No	Belt Tension*5	
		W	W1	X	X1	Y	Z	No of Teeth		Working	Max
AU BD 35 25...	TP20...& IP20...	49.5	47	25	27	12	39.4	27	DB 20 AT5...	560	5390
AU BD 50 25...	TP20...& IP20...	49.5	47	25	27	12	39.4	27	DB 20 AT5...	560	5390
AU BD 44 34...	TP25...& IP25...	67	67	30	32	15	56.8	20	DB 25 AT10...	1225	12450
AU BD 60 34...	TP25...& IP25...	67	67	30	32	15	56.8	20	DB 25 AT10...	1225	12450
AU BD 76 34...	TP25...& IP25...	67	67	30	32	15	56.8	20	DB 25 AT10...	1225	12450

Notes:

- For load capacities see Standard Carriages page in main GV3 catalogue. It is strongly recommended that load and life are determined using the methods shown in the Load/Life Calculations section of the main GV3 catalogue.
- Some dimensions vary by the amount of the grinding allowance according to the grade of Slide selected. All Carriages are compatible with all grades of Slide.
- Controlled Height (CHK) Bearings are usually selected from stock, quantities available may therefore be restricted. Please refer to 38 of this guide. Customers requiring CHK Bearings within the same tolerance band in respect of a number of Carriages should state this on their order.
- Carriages are available in two standard lengths, therefore Bearing centres 'D' and the number and position of component mounting holes 'G' will vary accordingly. Hepco will make Carriages to your special length requirements on request.
- The Max belt tension stated relates to the breaking load, and is provided for comparison purposes only. The working belt tension should not be exceeded when used with Hepco pulleys and grippers.
- The removable option is not available in conjunction with Cap Seals.
- The IP 25 P15 idler pulley is fitted with 2-off 6302 2RS deep groove ball Bearings (C = 11400N, Co = 5400N per Bearing). The IP 20 P12 idler pulley is fitted with 2 off 6001 2RS deep groove ball Bearings (C = 5070N, Co = 2360N).

The Belt Driven Carriage incorporates an integral **Belt Gripper & Tensioner** at each end. The Gripper securely holds the toothed belt and the fixing screws allow controlled pretensioning and adjustment.

In addition to the Carriage, Hepco will supply the necessary belt and pulleys to complete the system. Belts are steel reinforced polyurethane, and have the high strength AT tooth profile. Bored drive pulleys with zero backlash AT profile teeth are available in one size to provide a useful driving ratio for most applications. Idler pulleys are plain without teeth and are supplied complete with fitted deep groove ball Bearings, ready to fit onto a shaft.

Customers wishing to run the Carriage on a Flat Slide must specify the counterbored Slide fixing hole option as the belt would otherwise foul the heads of the screws.

Customers requiring a beam mounted Belt Driven Carriage with pulleys should consider the **Hepco DLS Linear Transmission**, which is a complete ready to mount positioning system including drive motor if required.

See Application Examples on 13, 14 & 16 of the GV3 catalogue

Example: Short Carriage with Lubricators on a Flat Slide

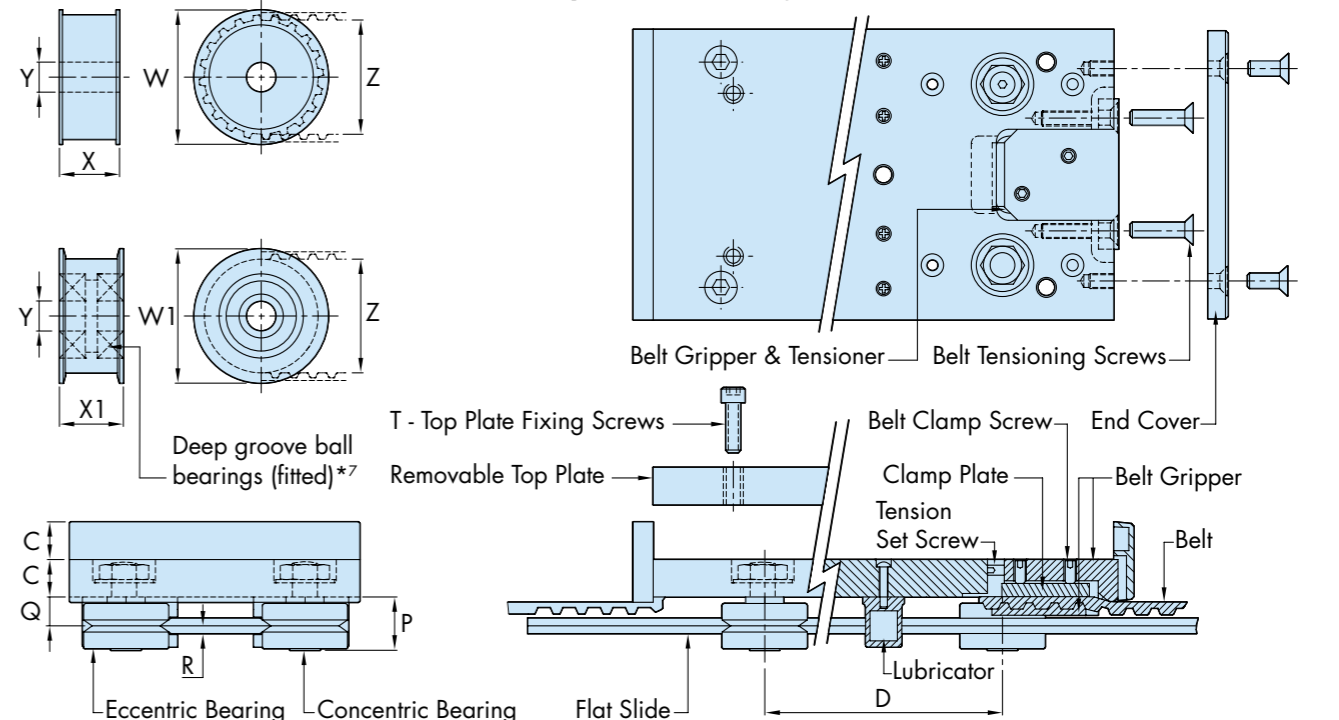

Part Number	L*4	LP*4	M	N*2			P	Q	R*2		S	T*4		U	V*4		
				P1 & P2	P3	P1			P2 & P3								
AU BD 35 25...	150	230	138	218	8x3	25	25.4	16.6	9	2.4	2.5	55	4xM6	5xM6	70	97	180
AU BD 50 25...	160	240	148	228	10x3.5	40	40.4	16.6	9	2.4	2.5	55	5xM6	5xM6	88	112	192
AU BD 44 34...	200	280	184	264	8x3	26	26.4	21.3	11.5	3.1	3.2	70	5xM8	5xM8	90	130	215
AU BD 60 34...	224	304	208	288	10x3.5	42	42.4	21.3	11.5	3.1	3.2	70	5xM8	5xM8	109	156	236
AU BD 76 34...	244	344	228	328	12x4	58	58.4	21.3	11.5	3.1	3.2	70	5xM8	5xM8	124	188	288

Ordering Details

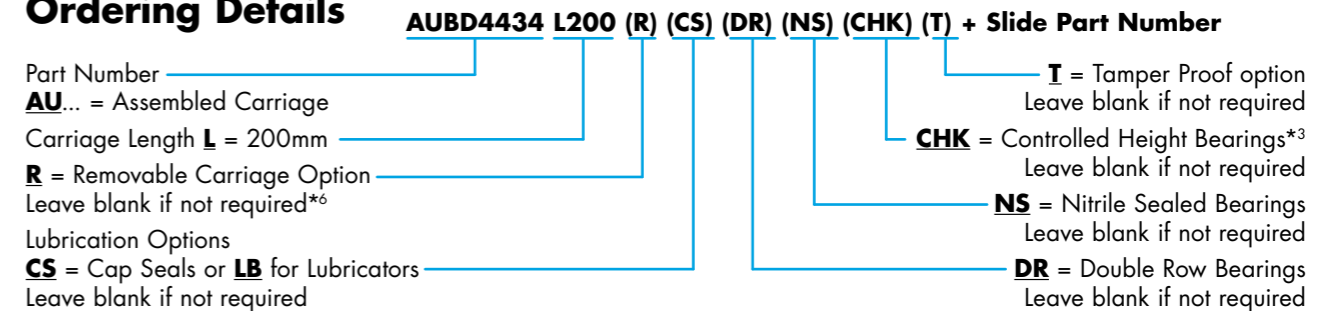

Ordering Examples for Pulleys & Belts:

- TP 20 AT5 T27 P12 0 **Toothed Drive Pulley** for 20 mm wide AT5 belt with 27 teeth & 12 mm plain bore
- TP 25 AT10 T20 P15 0 **Toothed Drive Pulley** for 25 mm wide AT10 belt with 20 teeth & 15 mm plain bore
- IP 20 P12 **Idler Pulley** for 20 mm wide belt with fitted Bearings to run on 12 mm Ø shaft
- IP 25 P15 **Idler Pulley** for 25 mm wide belt with fitted Bearings to run on 15 mm Ø shaft
- DB 20 AT5 L2345 **Drive Belt** 20 mm wide with AT5 tooth profile. **L2345** is the required length in mm
- DB 25 AT10 L3456 **Drive Belt** 25 mm wide with AT10 tooth profile. **L3456** is the required length in mm





HepcoMotion End Stops provide a physical stop to the linear movement and impact protection should a system overrun. The conical buffer provides a controlled deceleration to the Carriage to protect the system and payload. End Stops are suitable for GV3 Spacer and Flat Slides from 25 to 120mm wide, and can be positioned anywhere along the length of a Slide, for maximum flexibility.

See Application Example on 11 of the GV3 catalogue

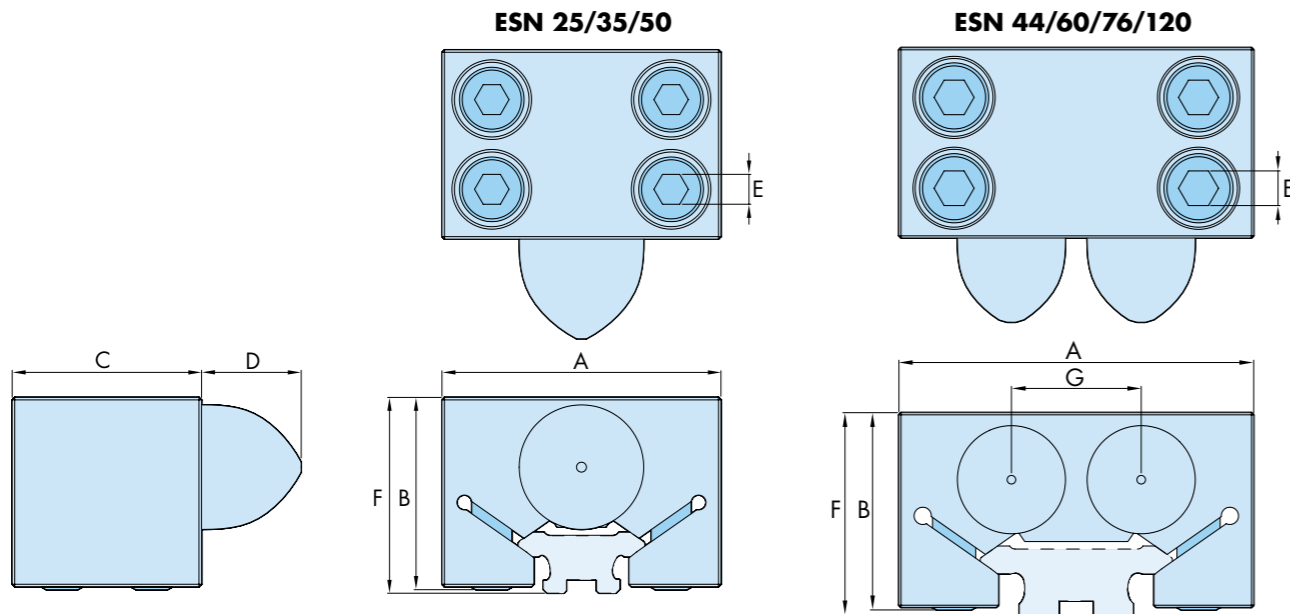

Part Number	Use With		A	B	C	D	E	F	G
ESN S25	NS25	S25	56	38.6	38	19	6	39.5	-
ESN S35	NS35	S35	69	38.6	38	19	6	39.5	-
ESN S50	NS50	S50	84	38.6	38	19	6	39.5	-
ESN M44	NM44	M44	82	45.6	44	19	8	46.5	30
ESN M60	NM60	M60	100	45.6	44	19	8	46.5	44
ESN M76	NM76	M76	118	50.6	44	19	8	51.5	50
ESN L76	NL76	L76	122	67.6	48	40	10	68.5	50
ESN L120	NL120	L120	164	72.6	60	40	10	73.5	90

Part Number	Clamping Screw Torque (Nm)	Maximum Static Force (N)*1	Maximum Impact Energy (J)**2
ESN S25	23	1000	6
ESN S35	23	1000	6
ESN S50	23	1000	6
ESN M44	47	2000	18

Part Number	Clamping Screw Torque (Nm)	Maximum Static Force (N)*1	Maximum Impact Energy (J)**2
ESN M60	47	2000	18
ESN M76	47	2000	18
ESN L76	80	6000	36
ESN L120	80	6000	36

Ordering Details

ESN indicates End Stop **ESN M44** **M44** = To suit Slide size

- Notes:
- Indicates maximum force that can be applied to the GV3 End Stop under gradual application.
 - Indicates maximum energy that can be absorbed by the GV3 End Stop under sudden impact conditions.
 - GV3 End Stops are intended for infrequent impacts. Please refer to 33 and the HepcoMotion SH Shock Absorber catalogue for units suitable for repeated impacts.
 - To fit End Stop sizes ESNS25, ESNS35 and ESNS50 to non-counterbored GV3 Flat Slides, the End Stops must be fitted before the fixing screws for mounting the Flat Slide.



HepcoMotion SH Shock Absorbers are a cost effective means of significantly increasing the life of a GV3 system, by reducing stress on the internal elements and fixings, as well as by reducing wear on the Slide in the crucial deceleration zone. Hepco Shock Absorbers will allow higher operating speeds to be achieved, reduce maintenance costs, lower noise levels, and enhance safety in the event of control system failure. Shock Absorber Fixing Blocks are supplied, ready assembled to the Spacer Slide, to provide a strong fixing capable of withstanding high deceleration forces. They are compatible with Standard, Removable and Slimline Carriages.

Smaller sizes of Fixing Block (see table) are bolted directly to the end of the Slide whilst larger sizes are bolted to the top surface. The top surface mounting position is normally at the end of the Slide, as shown, but may be specified at any position. This may be useful in cases where a number of Carriages run on the same Slide. Top surface mounting Fixing Blocks can also be used with Flat Slides. In this case the Slide is supplied drilled clearance for the screws and it will be necessary for customers to provide tapped fixing holes in the mounting surface of their machine.

Details of Shock Absorbers may be found in the Hepco SH Shock Absorber catalogue. They should be ordered separately, complete with the Soft Pad option.

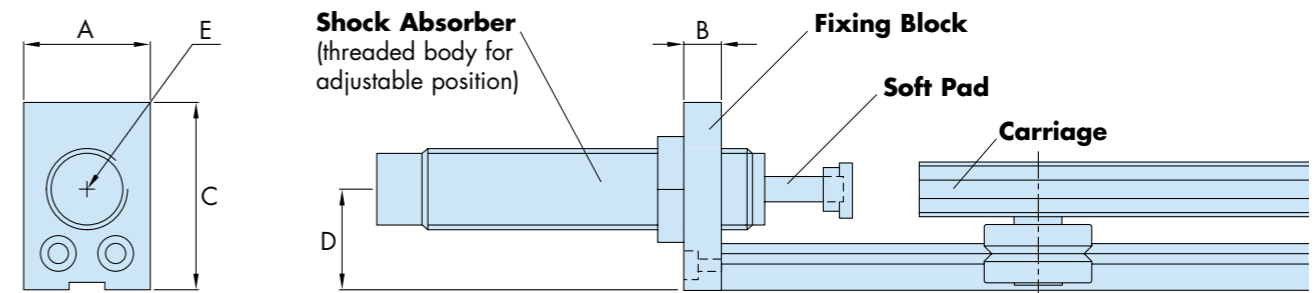

Fixing Block Part Number	Use With		A	B	C	D	E
SHBS 35 20	NS 35	SH20	30	12	40	25.5	M20 x 1.5
SHBS 50 20	NS 50	SH20	40	15	45	26.1	M20 x 1.5
SHBS 50 25	NS 50	SH25	40	15	45	26.1	M25 x 1.5
SHBM 44 20	NM 44	SH20	40	15	50	31.4	M20 x 1.5
SHBM 44 25	NM 44	SH25	40	15	50	31.4	M25 x 1.5
SHBM 60 20	NM 60	SH20	44	15	50	32.7	M20 x 1.5
SHBM 60 25	NM 60	SH25	44	15	50	32.7	M25 x 1.5

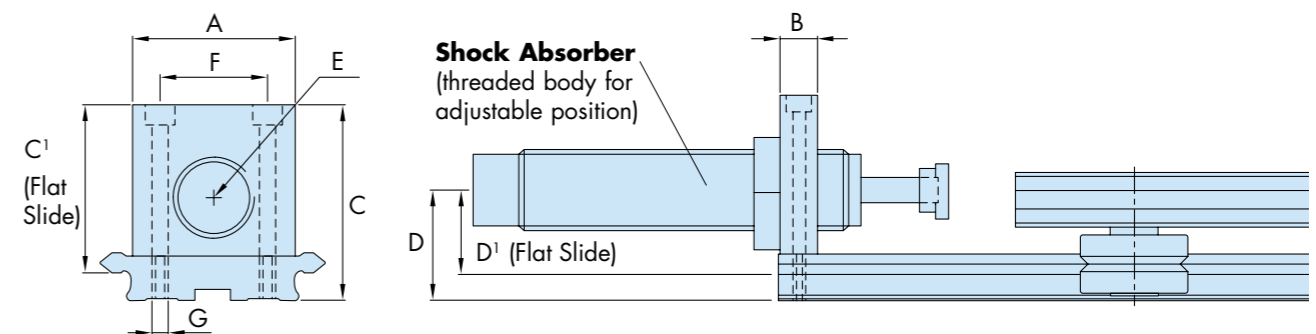

Fixing Block Part Number	Use With		A	B	Max (with P2/P3 Slide)				E	F	G
					C	C'	D	D'			
SHBM 76 20	NM & M 76	SH20	55	15	65.2	56.5	33.3	24.5	M20 x 1.5	37	M8
SHBM 76 25	NM & M 76	SH25	55	15	65.2	56.5	33.3	24.5	M25 x 1.5	37	M8
SHBL 76 20	NL & L 76	SH20	55	15	73.7	59.5	49	34.7	M20 x 1.5	37	M8
SHBL 76 25	NL & L 76	SH25	55	15	73.7	59.5	49	34.7	M25 x 1.5	37	M8
SHBL 120 20	NL & L 120	SH20	90	15	73.7	59.5	50.7	36.4	M20 x 1.5	70	M8
SHBL 120 25	NL & L 120	SH25	90	15	73.7	59.5	50.7	36.4	M25 x 1.5	70	M8
SHBL 120 36	NL & L 120	SHA3625/3650	90	15	73.7	59.5	50.7	36.4	M36 x 1.5	70	M8

Ordering Details

Slide Part Number **L120L1616P2** + **1 x SHBL12036**
 Fixing Block Part Number
 Quantity (1 x one end, 2 x = both ends)

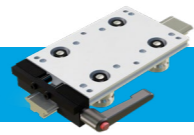

The HepcoMotion Carriage Locking Device has been designed to provide a safe and simple method of manually locking a Standard Carriage in position to facilitate processes where a secure, stationary platform is required. It is available factory assembled in Standard Carriage format only for sizes AU2525 and above.

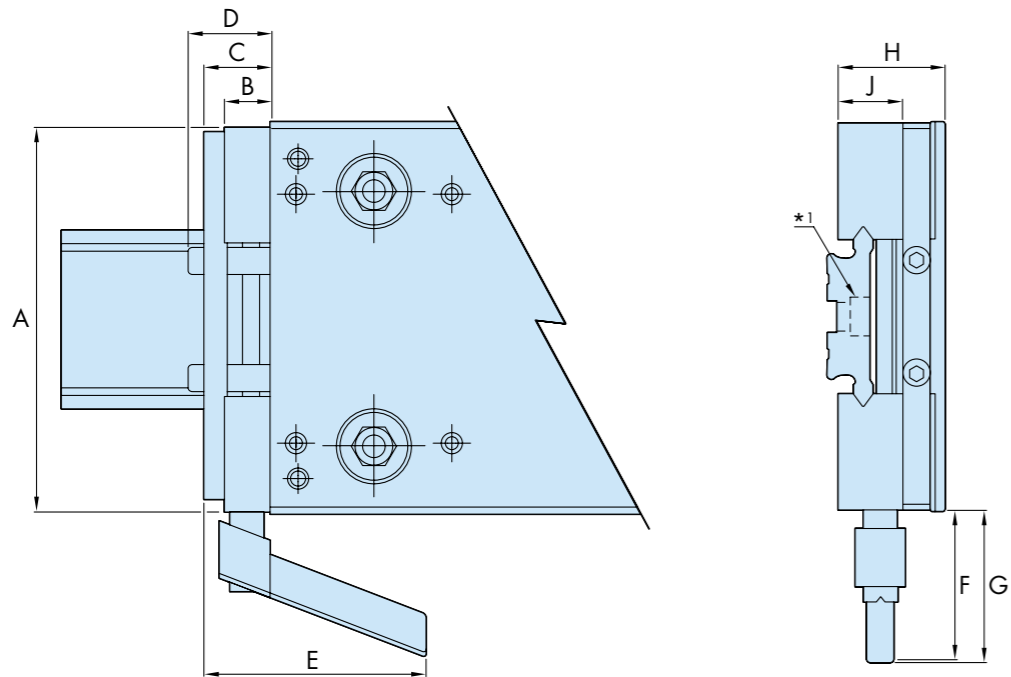
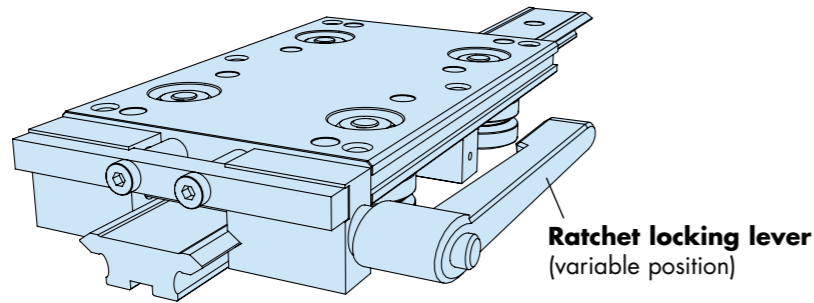

Part Number	Use With	A	B	C	D	E	F	G	H	J	Weight/g	
											S FC	L FC
BK 25 25	AU 25 25...	78	16	21.5	26.5	57	33.5	37.0	28.0	18.4		
BK 35 25	AU 35 25...	88										
BK 50 25	AU 50 25...	103										
BK 44 34	AU 44 34...	116	16	23.5	29.5	83	51.5	55.0	35.0	22.4		
BK 60 34	AU 60 34...	132										
BK 76 34	AU 76 34...	148										
BK 76 54	AU 76 54...	164	20	33.5	41.5	105	53.0	57.0	54.0	34.9		
BK 120 54	AU 120 54...	208										

Ordering Details

AU2525 L180 (CS) (DR) BK2525 + Slide Part Number*

Carriage Plate order details **BK...** = Carriage Locking Device option

Ordering Example: 2 x (3 x AU6034 L200 LB DR BK6034 + NM60 L3056 P) (2 systems each with 3 Carriages per Slide)

Notes:
1. Due to the limited clearance between Locking Device components and the Slide, all Slides with Locking Devices must have counterbored holes.



HepcoMotion Flange Clamps enable Slides to act as a self supporting elements of a machine. The Long Flange Clamp (type LFC) enables short lengths of Slide to be supported from one end only. Flange Clamps are fully machined from aluminium alloy and are supplied anodised.

Please refer to the Deflection of Self Supporting Slides calculations section on 33.

Assembly

Flange Clamps should be positioned proud of the ends of the Slide*. Flange fixing screws should be located and slightly tightened, before clamping screws 'M' are fully tightened. Progressive tightening of each screw 'M' is recommended. Flange fixing screws may then be fully tightened.

See Application Examples on 12 & 16 of the GV3 catalogue

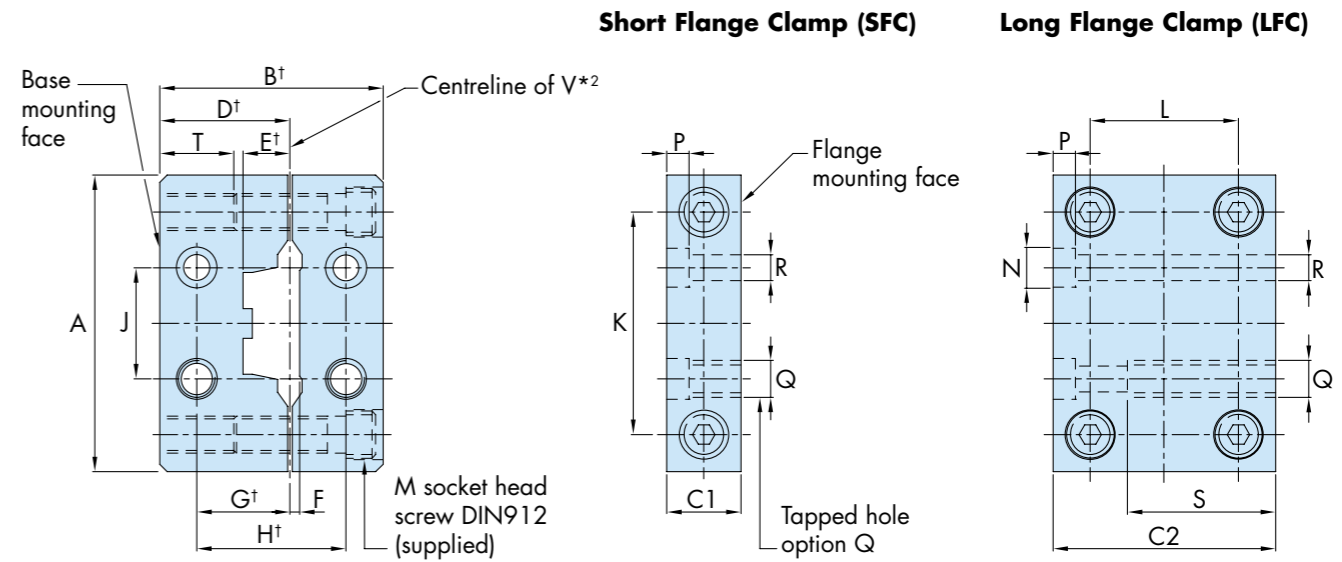

Dimensions marked † will differ slightly between application with P1 and P2 & P3 slides*2

Part Number*3	Use With	A	B	C1	C2	D*2	E*2	F	G	H	J	K	L	M	N	P	Q	R	S	T	Weight/g	
																					S FC	L FC
S/L FC 25	NS25	60	55	15	55	30	10	1.8	20	35	20	45	35	M6x30	9.5	5	M8	6	35	17	120	405
S/L FC 35	NS35	76	62	20	60	37	10	1.8	25	40	26	56	40	M8x35	11	6	M10	7	30	17	240	740
S/L FC 50	NS50	86	62	20	60	37	10	1.8	26	42	32	66	40	M8x35	11	6	M10	7	30	17	260	770
S/L FC 44	NM44	80	60	20	60	35	12.5	2.5	25	40	30	60	40	M8x30	11	6	M10	7	40	20	220	630
S/L FC 60	NM60	100	62	25	75	37	12.5	2.5	27	42	40	78	50	M8x35	11	6	M10	7	40	17	370	1150
S/L FC M76	NM76	127	75	25	75	50	12.5	2.5	30	45	55	95	50	M10x40	14	8	M12	9	45	23	530	1780
S/L FC 76	NL76	120	75	25	75	45	19.5	4	30	50	55	95	50	M10x40	14	8	M12	9	45	23	500	1430
S/L FC 120	NL120	170	100	25	75	62.5	19.5	4	35	54	95	140	45	M12x50	17	11	M16	11	40	35	1050	2750

Ordering Details

S FC60 (Q)

Clamp Length **S** = Short Type (use one at each end of Slide)
L = Long type (use for cantilever Slide mounting)

Q = tapped hole option is required
 Leave blank for through hole fixing

Part Number (**60** = nominal Slide width in mm*3)

Notes:

- For mounting Slides between opposing faces, Slides should be ordered 2 mm shorter than the required span.
- The drawings show dimensions from the centreline of the Slide 'V' when in the clamped condition. The figures quoted are valid for precision grades P2 & P3. For P1 Slides, dimensions D & E will be reduced by 0.2mm and dimensions B & H will be reduced by 0.4 mm. The keyway register ensures the Slide is located centrally.
- Flange Clamps are available to suit both the NM76 and NL76 Slides. For the NM76 compatible Flange Clamp, please state S/L FC M76 as per table.
- Standard drilled Flange Clamps will be reworked for customers requiring tapped hole option 'Q'.



HepcoMotion Axial Stiffness bearings have been developed for applications where system height needs to be stable under deflection and vibration. They are stiffer under axial (LA) loading and are also more resistant to any relaxation in system preload than a similar system using standard HepcoMotion Double Row type (DR) bearings. This makes them well suited to precise applications, particularly busy ones.

DR type bearings should remain the first choice for heavily loaded systems, however, for light and moderately loaded systems, Axial Stiffness type (AS) bearings can provide performance benefits.

The size 40 AS bearing complements the range by providing enhanced load capacity and life, whilst minimising system size. Axial Stiffness bearing sizes 25 and 34 are also available in stainless steel, interchangeable with standard GV3, SL2 and PRT2 bearings, and compatible with standard carriages plates and lubrication devices. Please refer to the table overleaf for information on compatibility with Hepco slides.

The following bearing format is available, with a through-hole fixing and nitrile seals:

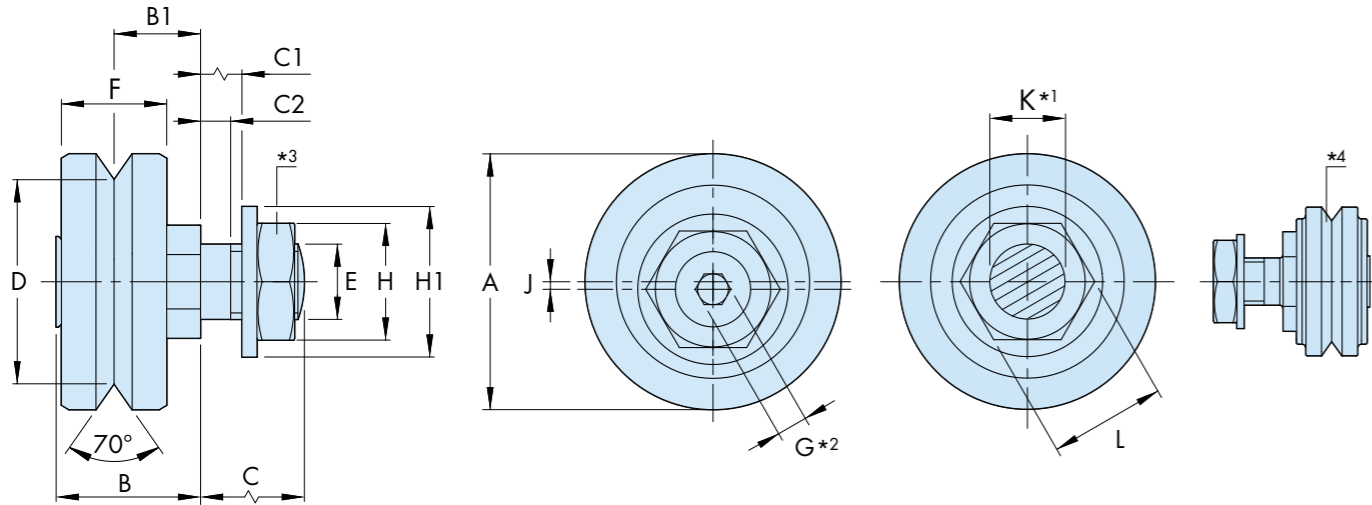

Part Number	A	B	B1	C		C1		C2		D	E	F	G	H	H1	J		K*1	L
				Short Axle	Long Axle	Short Axle	Long Axle	Short Axle	Long Axle							...E...	...DE...		
... UJ 20 ...	20	11.7	6.75	7.4	14	3.4	10	2.4	2.5	15.27	M6x0.75	9	2.5	10	13	0.7	2.6	6	11
... UJ 25 ...	25	15.5	9	9.8	19	3.8	13	3.4	4.9	20.27	M8x1	11	3	13	17	0.75	2.75	8	13
... UJ 34 ...	34	19.2	11.5	13.8	22	6.6	14.8	5.2	5.9	27.13	M10x1.25	14	4	17	21	1	3.6	10	15
... UJ 40 ...	40	20.5	11.5	18.6	26.8	8.6	16.8	6.5	7.2	32	M14x1.5	15.9	6	22	28	1	5.5	14	24

To help facilitate bearing type selection, key attributes of Hepco Twin, Double Row and Axial Stiffness bearings are compared in the chart below:

Bearing Type	Max Working Load Axial	Max Working Load Radial	Speed	Smoothness	Tolerance to Misalignment	Mass	System Height	Tolerance to Debris	Stiffness Under Axial Load
Twin	Low	Low	Low	Low	Low	Low	Low	Low	Low
Double Row	Medium	Medium	Medium	Medium	Medium	Medium	Medium	Medium	Medium
Axial Stiffness	High	High	High	High	High	High	High	High	High

Visual Comparison and Interchangeability of Size 25 and 34 Bearings:

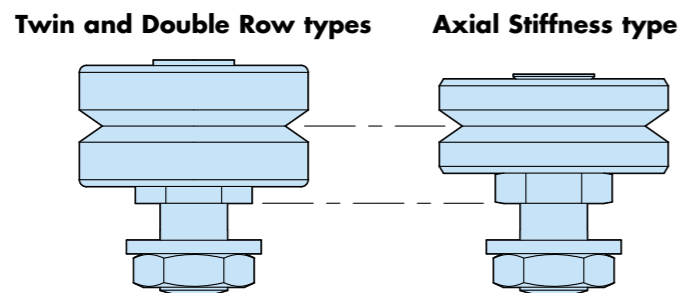

Load / Life Calculations

The maximum axial (LA) and radial (LR) working load capacities, in Newtons, for all sizes of Hepco AS type bearings, are given in the table below. Values are based on shock-free duty.

All bearings are greased internally for life. Customers should provide lubrication to the interface between bearings and slide. This can be achieved using Hepco Slide Lubricators or Cap Seals. Lubrication maximises load capacity and life.

To calculate system life, the load factor Lf should first be calculated by using the equation below and capacities in the table provided.

Lf should not exceed 0.5 for any combination of loads on Axial Stiffness bearings.

Life, in kilometres, can then be calculated using the second equation. The value for Basic Life is also taken from the table.

Part Number	Maximum Working Load (N)		Basic Life (km)
	LA(max)	LR(max)	
... UJ 20 ...	320	800	65
... UJ 25 ...	370	1350	85
... SS ... UJ 25 ...	290	1080	70
... UJ 34 ...	710	2000	570
... SS ... UJ 34 ...	570	1600	425
... UJ 40 ...	1200	2300	640

$$L_f = \frac{L_A}{L_{A(max)}} + \frac{L_R}{L_{R(max)}} \leq 0.5$$

$$Life (km) = \frac{Basic Life}{(0.03 + 0.97L_f)^3}$$



Compatible Slides, Lubrication Devices, Adjusting Tools and Tightening Torques

Part Number	...20...	...25...	...34...	...40...
Preferred Slide Size*5	NV & V	NS & S	NM & M	NM & M
Slide Lubricator	LB20	LB25	LB44	LB44
Cap Seal	-	CS25	CS34	-
Adjusting Wrench*6	AT18	AT25	AT34	AT40
Socket Tool*6	RT6	RT8	RT10	RT14
Fixing Nut Torque	7Nm	18Nm	33Nm	33Nm

Ordering Details

(R) (SS) SUJ 25 C DR NS

R = PRT2 version (Leave blank for GV3/SL2)
 Stainless steel option [Size 25 and 34 only] (Leave blank if not required)
 Fixing type: **SUJ** = Short axle, **LUJ** = Long axle
 Part number (~ Bearing diameter in mm)

NS = Nitrile Sealed Bearing (As standard for Axial Stiffness bearings)
DR = Double Row Bearing (As standard for Axial Stiffness bearings)
C = Concentric (fixed),
E = Eccentric (adjustable, GV3/SL2 only),
DE = Double Eccentric (adjustable, PRT2 version only)

Notes:

- It is recommended that holes to suit bearing mounting axles should be reamed to tolerance F6 for a sliding fit. Please note that dimension K for the size 40 AS bearing has a tolerance of +0.000/-0.011. All other sizes are as stated in the table.
- All eccentric Through Fixing type bearing axles are supplied with sockets for adjustment as shown in the GV3 Catalogue (Standard Bearings page 34).
- Nuts for the Through Fixing type bearings are chemically blacked on the concentric version and bright zinc plated on the eccentrics for identification purposes.
- The size 20 AS bearing has an alternative outer ring design, shown in the right-hand view of diagram on page 36.
- The preferred choices of slide to use with each bearing are quoted. For information on compatibility with other slide sizes, please contact Hepco's technical department.
- When ordering individual components for the first time, an Adjusting Wrench and Socket Tool should also be ordered. These are only available from Hepco.



HepcoMotion Controlled Height Bearings (CHK) are designed to minimise the variation in the 'V' height of Standard Bearings. This is desirable in high precision applications, and in Carriages using Double Row type Bearings.

Controlled Height (CHK) Bearings are available in five incremental $\pm 0.010\text{mm}$ bands, spanning a total of $\pm 0.050\text{mm}$ in respect of the B1 dimension. They are supplied in sets of up to 50 parts as standard, with larger sets on request.

CHK Bearings of differing bands should not be mixed in any Carriage assembly. In applications with multiple Carriages, it is recommended that Bearings with adjacent tolerance bands are used in Carriages that will be assembled next to each other.

To aid identification, Bearings are supplied with a colour coded mark located in the hexagon recess on the underside of the Bearing, as shown below.

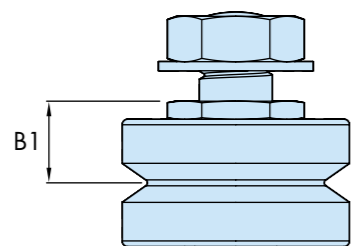

Identification Colours:



Identification Colour	B1 Tolerance	
	Band	B1
Red	A	-0.05
		-0.03
Orange	B	-0.03
		-0.01
Yellow	C	-0.01
		+0.01
Green	D	+0.01
		+0.03
Blue	E	+0.03
		+0.05

Ordering Details*1

LJ 25 C (DR) (NS) (CHK)

Bearing Part Number _____ **CHK...** = Controlled Height option

Notes:

1. A set of Bearings will be supplied within a single band. Bearings within a specific band are available on request.



HepcoMotion Floating Bearings are designed to provide axial movement (float) of the 'V' position; this is especially useful where 'V' Slides are mounted in parallel. The axial movement compensates for parallelism tolerances between the opposing V's, reducing the potential of additional loading and helping to maintain a consistent running quality.

Floating Bearings are available in three basic sizes to work easily with the GV3 range. They are available in two axle lengths covering most thicknesses of Carriage or mounting plate, the short axle version being compatible with Hepco Carriage Plates. Both versions are available in **Concentric type (C)**, which are fixed providing a datum (in radial direction) for the system, **Eccentric (E)** and **Double Eccentric type (DE)** to enable system adjustment, with the DE version having sufficient stroke to permit disengagement from the Slide.

For more information, or to suit a specific application, please contact Hepco's Technical Department.

Short axle (SFJ) / Long axle (LFJ)

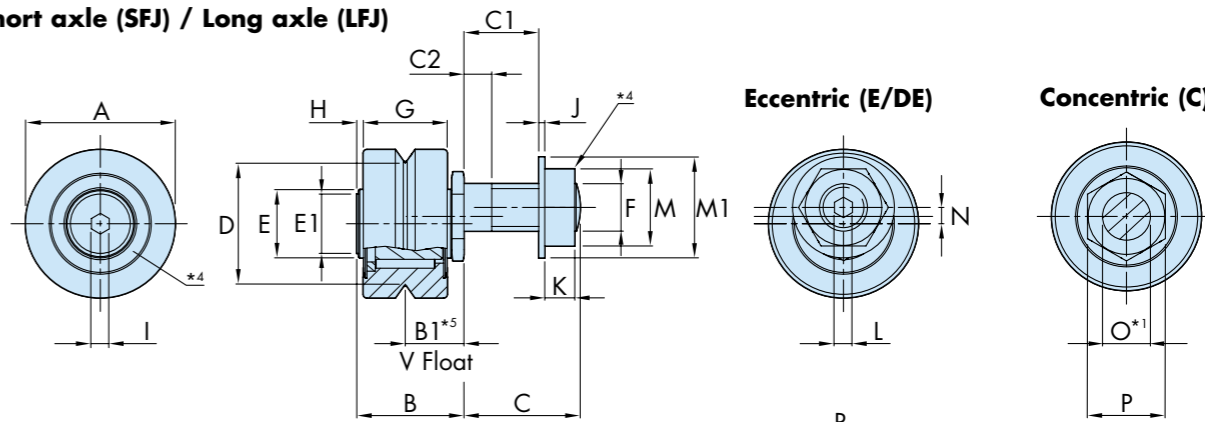

Floating Bearing Lubricator*6,7

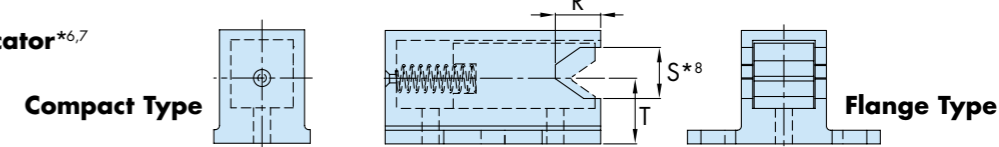

Part Number	Use With			A	B	B1*5		C	C1	C2	D	E	E1	F			
	NS	S	LB 25...FB			Min	Max								SFJ	LFJ	SFJ
...FJ 25...	NS	S	LB 25...FB	25	17.6	9	10.5	9.8	19	4	13	3.4	4.9	20.27	11.5	10	M8 x 1
...FJ 34...	NM	M	LB 44...FB	34	22.5	11.5	13.5	13.8	22	6	14	5.2	5.9	27.13	16	12	M10 x 1.25
...FJ 54...	NL	L	LB 76...FB	54	35.6	19	21.6	17.8	30	8	20	5.7	7.9	41.76	28	25	M14 x 1.5

G	H	I	J	K	L	M	M1	N*3		O*1	P	R	S*8	T	Adjusting Wrench	Socket Tool	Max Working Load Capacity (N)*2	Bearing Radial Load Capacities (N)*2	
								Eccentric	Double Eccentric									Static (Co)	Dynamic (C)
14	0.8	3	1	5	3	13	17	0.75	2.75	8	13	5.5	7.1	9	AT25	RT8	1500	6100	4900
18	1	4	1.25	6	4	17	21	1	3.6	10	15.2	8	9	11.5	AT34	RT10	3000	12500	11500
28	1.3	8	1.6	8	6	22	28	1.5	5.5	14	27	11.5	12.6	19	AT54	RT14	5000	28900	21500

Ordering Details

Fixing type _____ **SFJ 25 C NS**
 (Choose from: **SFJ** = Short Axle, **LFJ** = Long Axle)
25 = Bearing diameter _____
 (Choose from 25, 34 and 54)
C = Concentric (fixed), **E** = Eccentric (adjustable) or **DE** = Double Eccentric (for disengagement purposes)
NS = Nitrile Sealed Bearings

Ordering Examples for Floating Bearing Lubricator:

LB 25 C FB _____ Compact type (C) Lubricator for 25mm diameter Floating Bearing
 LB 44 F FB _____ Flanged type (F) Lubricator for 34mm diameter Floating Bearing

Notes:

1. It is recommended that holes to suit Bearing mounting axles should be reamed to tolerance F6 for a sliding fit.
2. The quoted static and dynamic load capacities use industry standard calculations and are only provided for comparison with other systems. Please use the Load/Life Calculation methods from the main GV3 catalogue. In all cases, Hepco Floating Bearings will have a life equal to or greater than the corresponding size of Double Row Standard Bearings. Floating Bearings are not designed to be axially loaded.
3. The 'N' dimension is the eccentric offset.
4. Fastenings are chemically blacked on the concentric version and bright zinc plated on the eccentric versions for identification purposes.
5. The variation in the 'B1' dimension is the min/max axial movement of the 'V' centre also referred to as 'V float'.
6. Two machine screws with cross-recessed pan heads to DIN7985A are supplied for fixing the flanged type Floating Bearing Lubricator. Additionally, two self-tapping screws for plastic with PT thread form and cross-recessed pan heads are supplied for compact type Lubricators.
7. Lubrication interval depends on length of stroke, duty and environmental factors. Replenish lubricant as necessary using a 68 viscosity EP mineral oil.
8. Dimension S accommodates the 'V' float of the Floating Bearings.



HepcoMotion Vacuum & Extreme Temperature Bearings [↗](#) and Track Rollers [↗](#) are designed for extreme environments. They are available in sizes from 18mm to 54mm in diameter, with a broad range of fixing styles, and with load capacities from 180N to 4,200N.

Hepco VACSS Vacuum & High Temperature Bearings are made entirely from stainless steel parts and are lubricated internally for life using Krytox LVP grease. They are suitable for use in high vacuums, at temperatures from -15°C to +210°C, and in the presence of oxygen. They are widely used in applications including semiconductor wafer manufacture, aerospace components, vapour deposition processes, LCD panel and plasma display manufacture and in vacuum evaporation equipment.

The Bearings have the same dimensions as GV3 Standard Bearings [↗](#).

The ...J18... VACSS Bearings have a different construction to the larger sizes, using a one piece outer wheel into which two smaller Bearings are fitted. This size is not available in the low temperature LTSS version.

These Bearings can be supplied with alternative grease, without grease or without shields, on request.

Through Fixing Type (SJ/LJ)

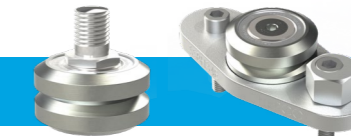
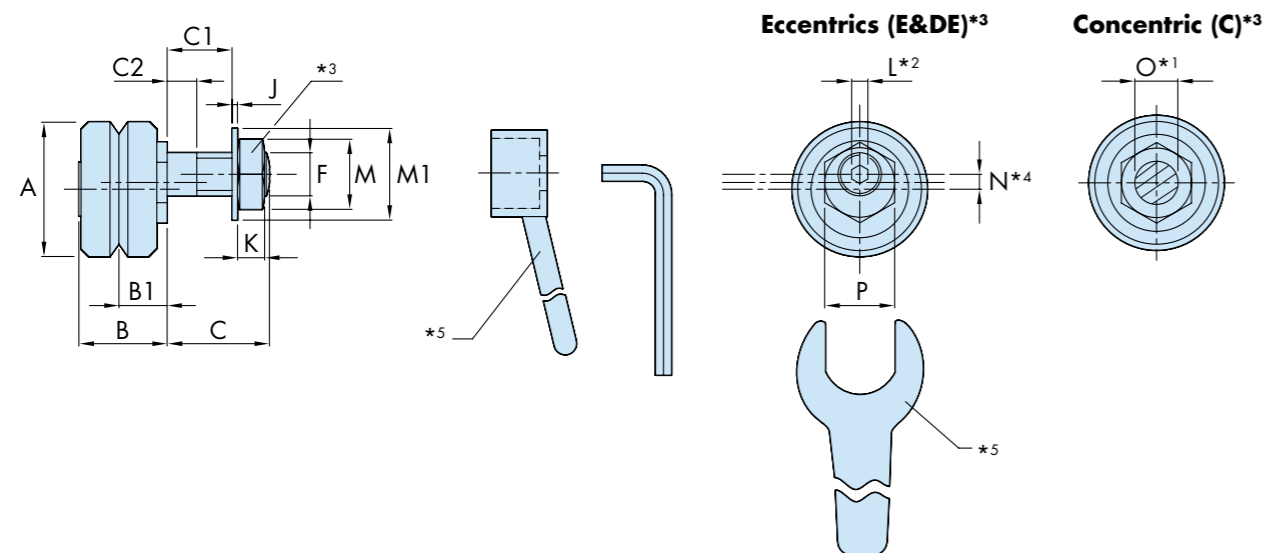

Hepco LTSS Low Temperature Bearings [↗](#) are lubricated internally for life using AeroShell Grease 22, which is suitable for use at temperatures from -50°C to +150°C. This lubricant enables use in much colder conditions than the VACSS Bearings, for applications such as cold stores and specialised freeze dry equipment.

Through Hole Fixing type is available in two axle lengths covering most thicknesses of mounting plate. Both are available in **Concentric type (C)** which are fixed, **Eccentric type (E)**, adjustable, and **Double Eccentric type (DE)**, which have sufficient adjustment to enable a Carriage [↗](#) to be disengaged from the Slide [↗](#).

Blind Hole Fixing type (BHJ) allows mounting into a solid machine base where through mounting holes are not possible, or where the thickness of the mounting plate is too great. The Blind Hole Fixing type is also useful where adjustment from the front is preferred or where access to the opposite side of the mounting hole is restricted. They are available in the fixed position **Concentric type (C)** and adjustable **Eccentric type (E)**.

Blind Hole Fixing Type (BHJ)

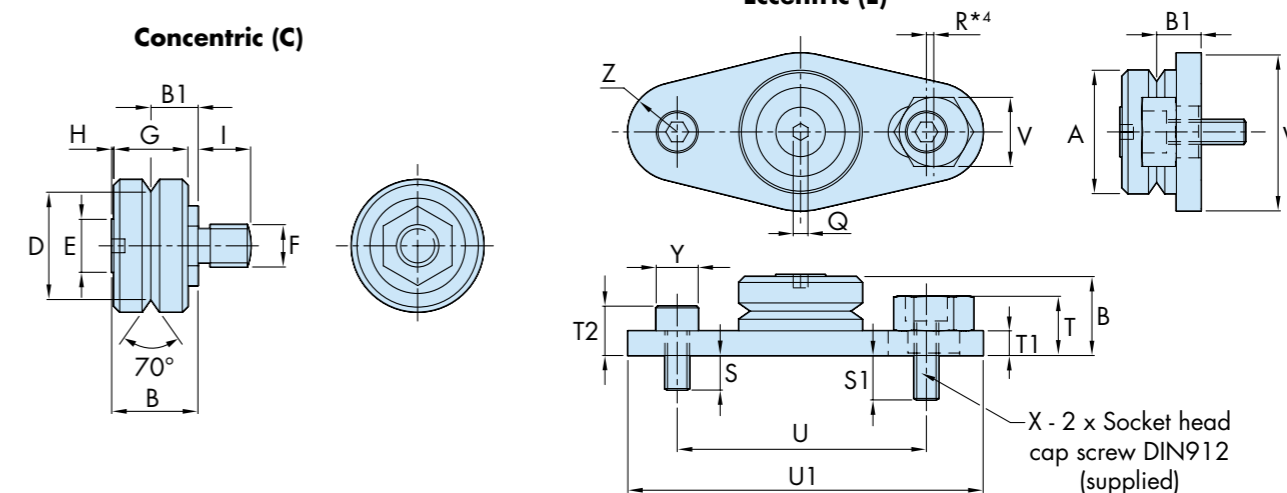

Part Number	A	B	B1	C		C1		C2		D ±0.025	E	F Metric Fine	G	H	I	J	K	L	M	M1	N*4		O*1 +0.0 -0.03	P
				SJ	LJ	SJ	LJ	SJ	LJ												...E	...DE		
... J 18 ...	18	12.4	6.75	7.4	14	3.4	10	2.4	2.5	14.00	7	M6 x 0.75	10	0.6	7.4	0.8	3.2	2.5	10	13	0.7	2.6	6	11
... J 25 ...	25	16.6	9	9.8	19	3.8	13	2.2	4.9	20.27	10	M8 x 1	14	0.5	9.8	1	5	3	13	17	0.75	2.75	8	13
... J 34 ...	34	21.3	11.5	13.8	22	6.6	14.8	5.2	5.9	27.13	12	M10 x 1.25	18	0.7	13.8	1.25	6	4	17	21	1	3.6	10	15
... J 54 ...	54	34.7	19	17.8	30	8.2	20.4	5.7	7.9	41.76	25	M14 x 1.5	28	1.6	17.8	1.6	8	6	22	28	1.5	5.5	14	27

Part Number	Q	R*4	S	S1	T	T1	T2	U ±0.1	U1	V	W	X	Y	Z	Adjusting Wrench*5	Socket Tool*5	Max Working Load Capacities (N)*6				Basic Life*6	
																	Lubricated		Dry		Lubricated	Dry
																	Axial	Radial	Axial	Radial		
... J 18 ...	2	1.2	8	10.5	10	4	8	38	54	11	24.5	M4	7	7	AT18	RT6	60	180	36	72	80	50
... J 25 ...	3	1.5	7	9	12	5	10	50	72	14	32	M5	8.5	10	AT25	RT8	240	450	80	160	50	70
... J 34 ...	4	2.0	9.5	8.5	17.5	6.5	12.5	60	90.5	17	42	M6	10	14	AT34	RT10	520	900	160	320	100	100
... J 54 ...	8	3.0	14.5	16.4	23.5	10.5	18.5	89.5	133	25	62	M8	13	20	AT54	RT14	1350	2400	360	720	250	150

Notes:

- It is recommended that holes to suit Bearing [↗](#) mounting axles should be reamed to tolerance F6 for a sliding fit.
- Eccentric Bearing fixing axles are supplied with hexagon sockets for adjustment as shown.
- Nuts and washers are supplied with both concentric and eccentric SJ/LJ type Bearings.
- 'N' is the eccentric offset due to the eccentric design (2 x N = total stroke). R dimension is both the eccentric offset of the adjusting nut and total stroke at the Bearing centreline.
- For adjusting tool part numbers see table. For adjustment procedure and fixing nut tightening torques [↗](#).
- To calculate the load capacity and life of systems using these Bearings, please use the methods shown in the Load/Life Calculations section of the GV3 catalogue [↗](#).

Ordering Details

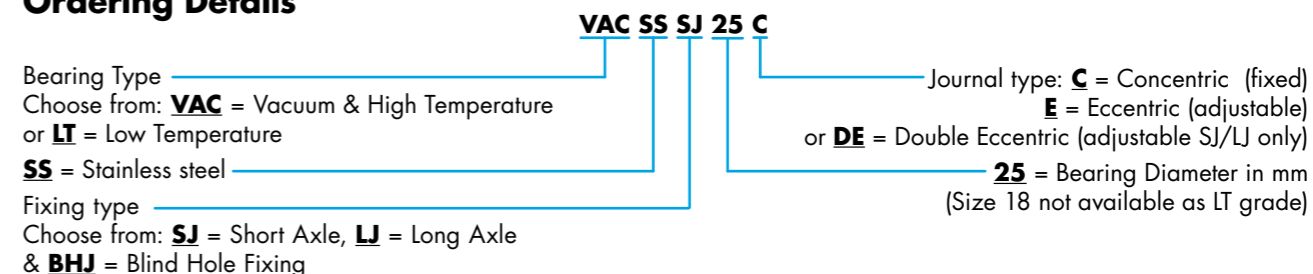



Vacuum & High Temperature and Low Temperature Track Rollers are available as fixed position **Concentric type (C)** and adjustable **Eccentric type (E)** on through hole fixing axles. They are available with 25mm, 34mm or 54mm diameters, and load capacities up to 4,200N. Track Rollers can be run with any suitable Flat Track, or can be used as cam followers. Materials and greases are the same as are used on the VACSS Vacuum & High Temperature and LTSS Low Temperature 'V' Bearings shown on the previous pages.

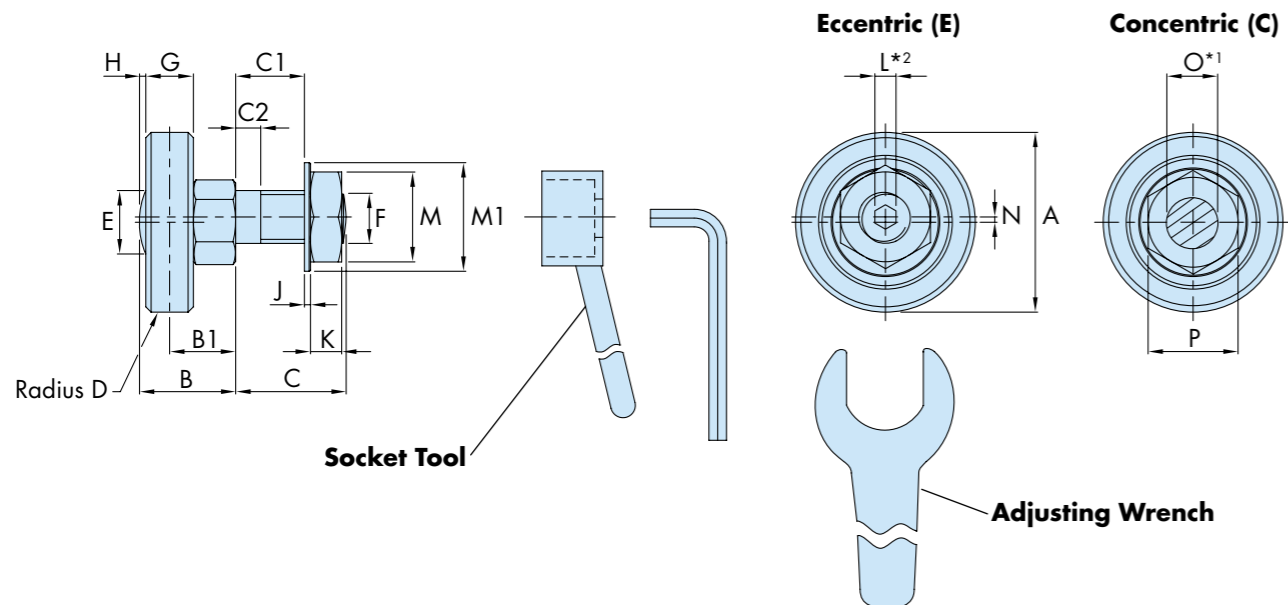

Part Number	A	B	B1	C	C1	C2	D	E	F Metric Fine	G	H	J	K
... LRN 25 ...	25	14.5	10	19	13	5	500	10	M8x1	7	1	1	5
... LRN 34 ...	34	18.2	12.5	22	14.8	6	500	12	M10x1.25	9	1.2	1.25	6
... LRN 54 ...	54	29.5	21	30	20.4	8	500	23.5	M14x1.5	14	1.4	1.6	8

Part Number	L*2	M	M1	N	O*1 +0 -0.03	P	Adjusting Wrench	Socket Tool	Max Working Load Capacity*4	Roller Static and Dynamic Radial Load Capacities (N)*3	
										Co	C
... LRN 25 ...	3	13	17	0.75	8	13	AT25	RT8	800	1092	2632
... LRN 34 ...	4	17	21	1	10	15	AT34	RT10	1400	1905	4078
... LRN 54 ...	6	22	28	1.5	14	27	AT54	RT14	4200	5319	10965

Ordering Details

Bearing Type VAC SS LRN25 C
 Choose from: **VAC** = Vacuum & High Temperature or **LT** = Low Temperature
SS = Stainless steel
C = Concentric (fixed) or **E** = Eccentric (Adjustable)
LRN = Indicates a Track Roller, **25** denotes the diameter in mm

Notes:

- It is recommended that holes to suit Track Roller mounting axles should be reamed to tolerance F6 for a sliding fit.
- Eccentric Track Roller fixing axles are supplied with hexagon sockets for adjustment as shown.
- The quoted static and dynamic load capacities are based on industry standard calculations. These do not accurately reflect system performance, and are only provided for comparison with other systems.
- To calculate the load capacity and life of systems using these Rollers, please use the methods provided in the Load/Life Calculations section of the GV3 catalogue.

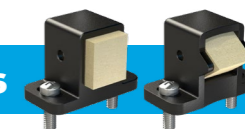

HepcoMotion Bearing Lubricators & Flat Track / Roller Lubricators*1 provide a simple and versatile means of applying lubricant to a system, and consist of a plastic housing incorporating a sprung loaded oil impregnated felt wiper. Bearing Lubricators are an alternative to Slide Lubricators for lubricating 'V' Slide Systems with Standard Bearings.

Bearing Lubricator

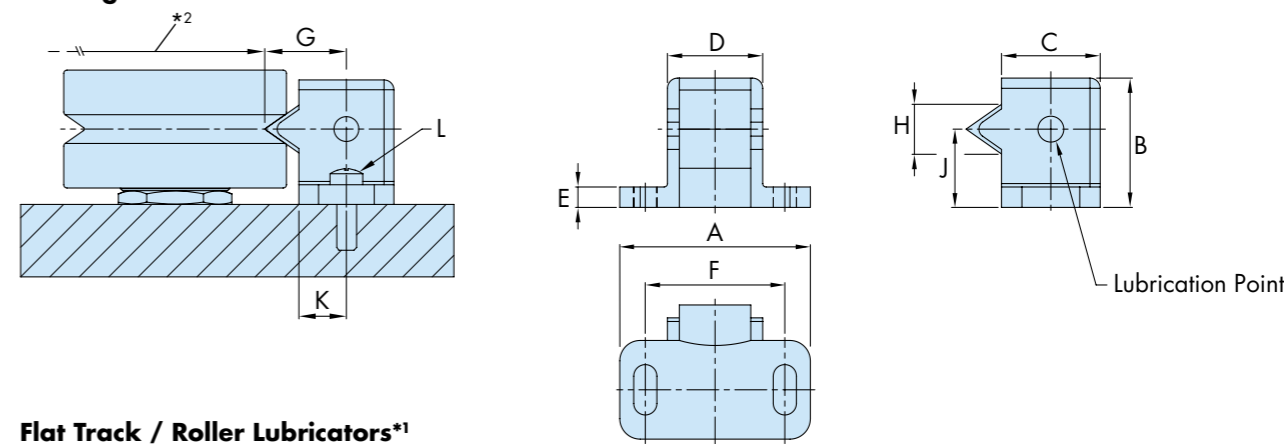

Flat Track / Roller Lubricators*1

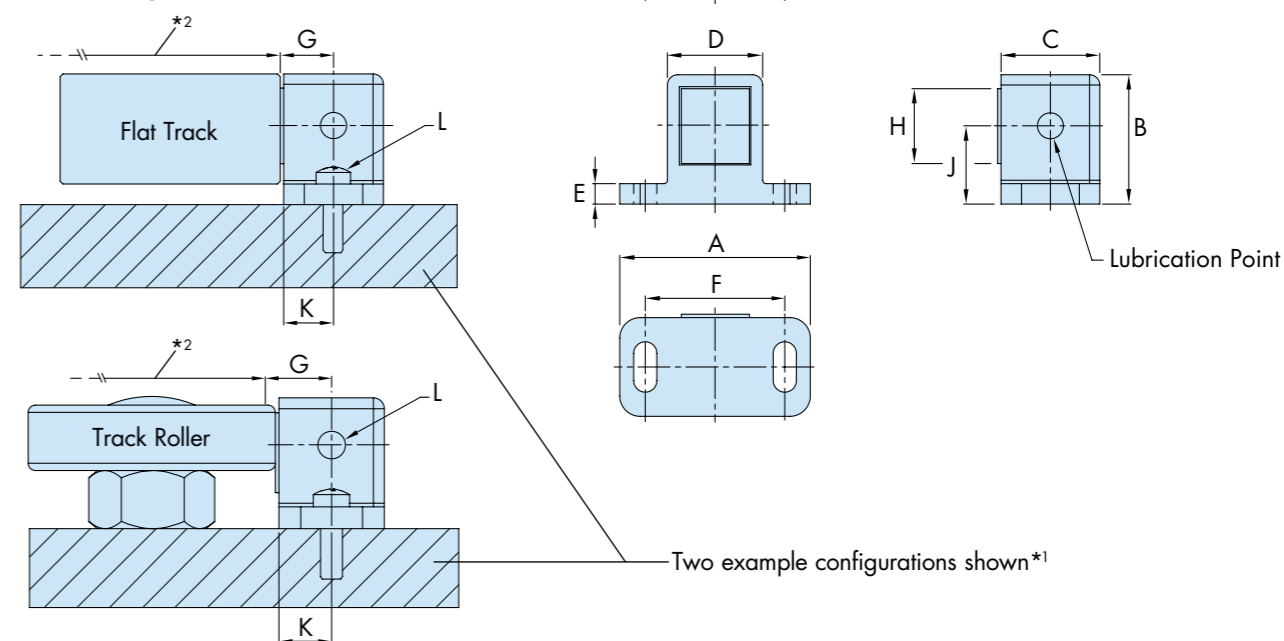

Part Number	For Use with			A	B	C	D	E	F	G	H	J	K	L
	Bearing	Track	Roller											
BLB 25	... J 25 ...	-	-	28	16	10.5	13.5	3	20.5	9.46	5.90	9	5.25	M3
RLB 25	... R 25 ...	FT 32 16	7.25							11				
NRLB 25	LRN 25 ...	FT 32 16	-	28	19	14.5	14	3	20.5	12.46	7.30	11.5	7.25	M3
BLB 34	... J 34 ...	-	9.25							11				
RLB 34	... R 34 ...	FT 40 20	-	42	32	18	21.5	5	32	18	12.6	19	9	M4
NRLB 34	LRN 34 ...	FT 40 20	11							21				
BLB 54	... J 54 ...	-	-	29	29	18	21.5	5	32	18	12.6	19	9	M4
RLB 54	... R54 ...	FT 66 33	11							21				
NRLB 54	LRN 54 ...	FT 66 33	-	-	-	-	-	-	-	-	-	-	-	-

Ordering Details

Part Number BLB 34

Notes:

- Wide Track Roller Lubricators can be used with both Wide Track Rollers and Flat Tracks. Narrow Track Roller Lubricators can be used with both Narrow Track Rollers and Flat Tracks.
- For drilling centres, see Data & Dimensions for Assembled Systems section 14-19.

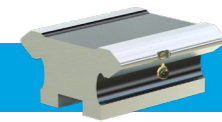

The HepcoMotion Bleed Lubrication facility enables a constant flow of lubricant to be channelled directly to the 'V' surfaces of the Slide. The lubricant is picked up and distributed by the Bearings whilst traversing the Slide. Lubricant distribution can be facilitated further by also fitting Hepco Cap Seals / Wipers or Lubricators, which will be continuously charged with fresh lubricant and ensure an even spread over the working surfaces.

As the lubricant is provided via the Slide rather than the Lubricators or Cap Seals, the number of lubrication devices fitted to each Carriage can be reduced within a system. It is recommended that one in four Carriages is fitted with Lubricators or Cap Seals in any system using bleed lubrication. This will reduce friction and running costs.

Inserts are available with either an M5 thread or 4mm diameter bore with O-ring seal.

Connection can be made to a centralised lubrication system, pressure feed canister or an oil dispensing pump and controller, which can be programmed to meter a set dose of lubricant according to the distance travelled by the Carriage.

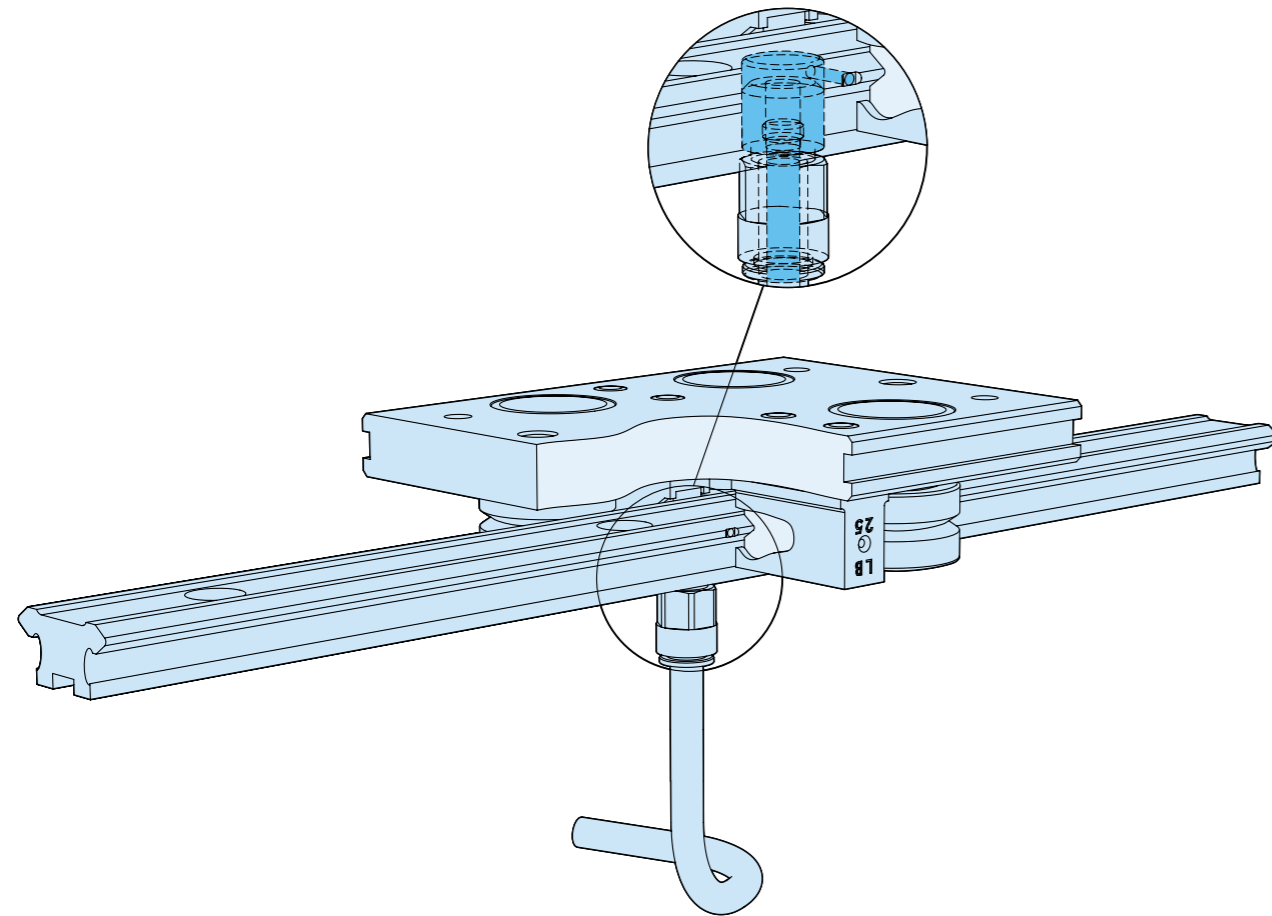

Below is an example of how the bleed lubrication facility can be incorporated into a typical application:

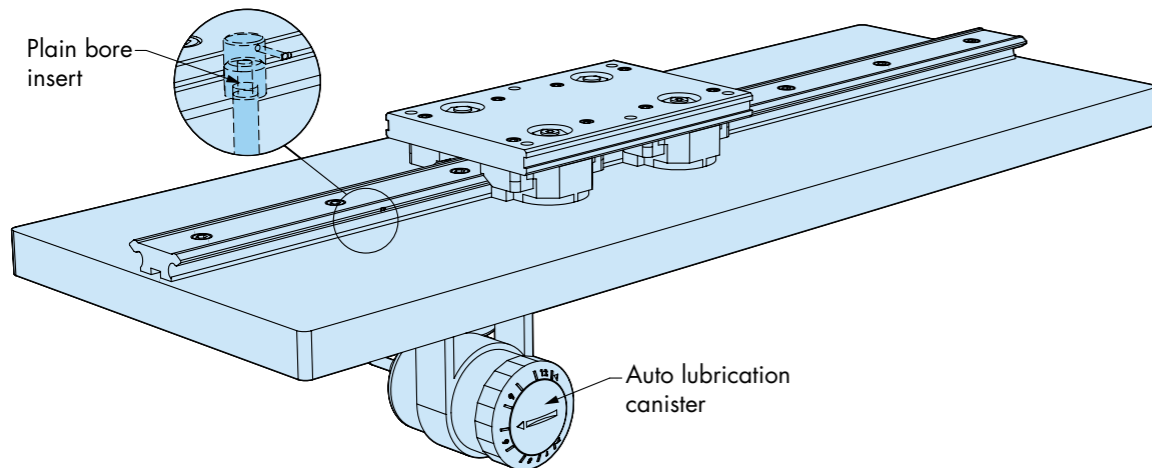

Double Edge Slides

Slides with dual bleed lubrication holes are shown below with details of their positions.

The Double Edge Slides are also available with single bleed lubrication holes, which can be positioned on either 'V'. Please specify at the time of ordering.

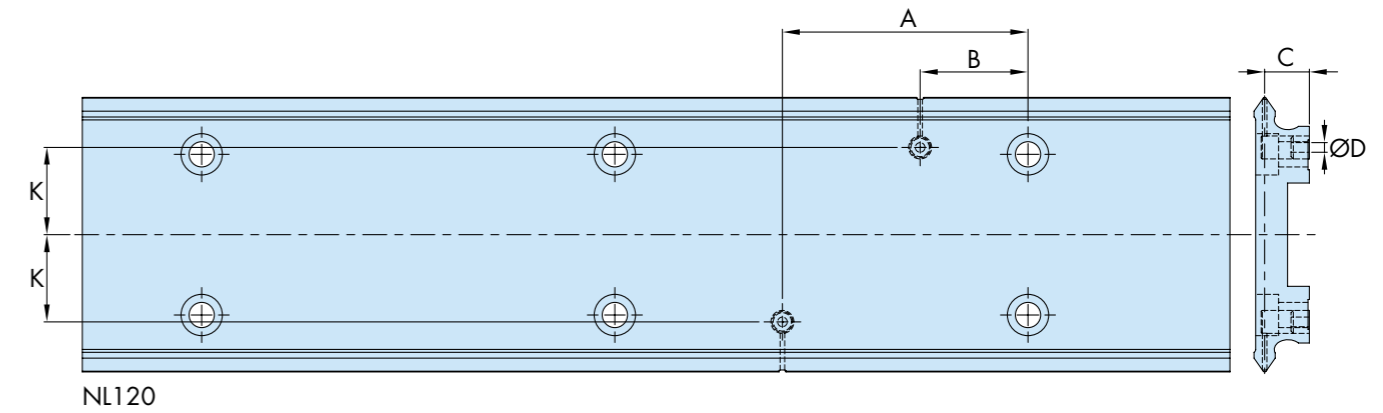
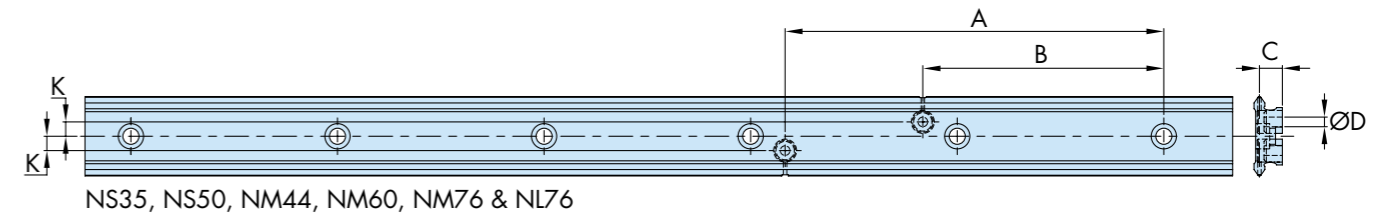
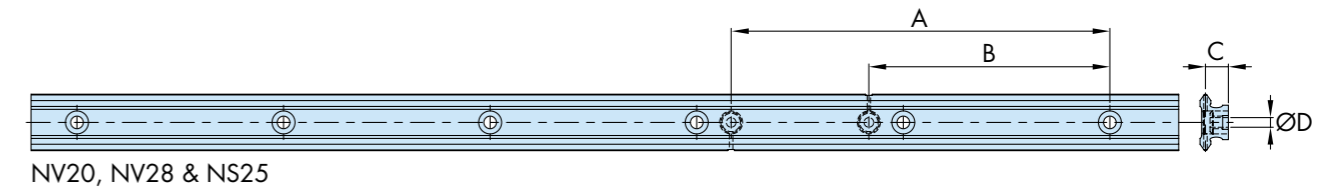

Single Edge Slides

Single Edge Slides are also available with the bleed lubrication facility. Details of their positions are shown below.

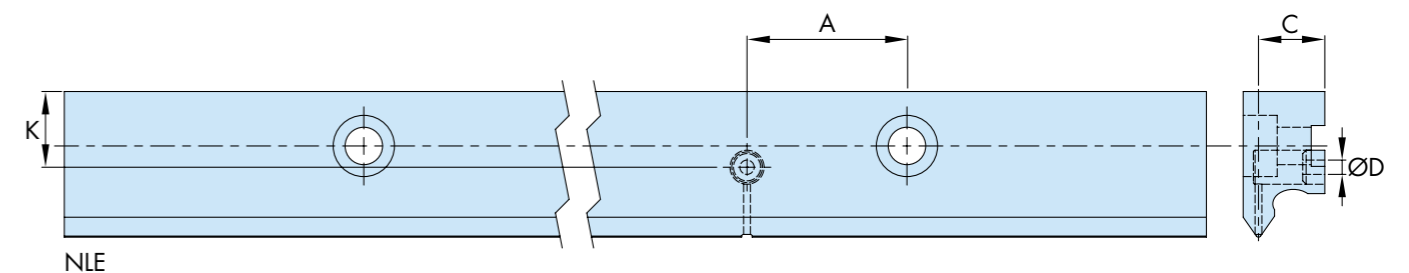
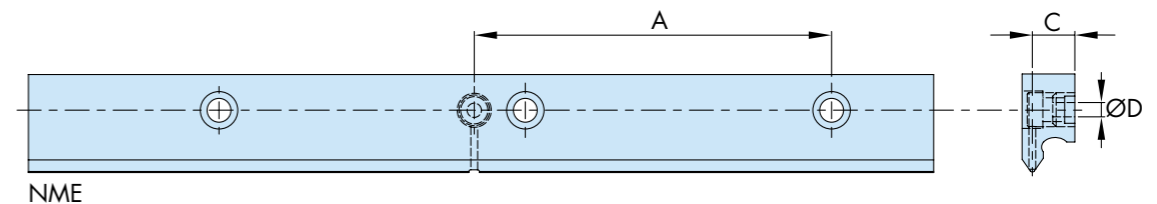
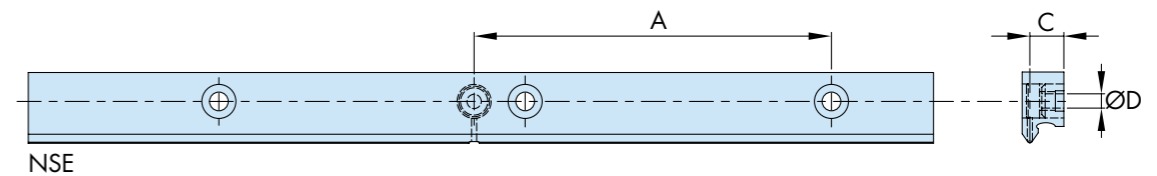

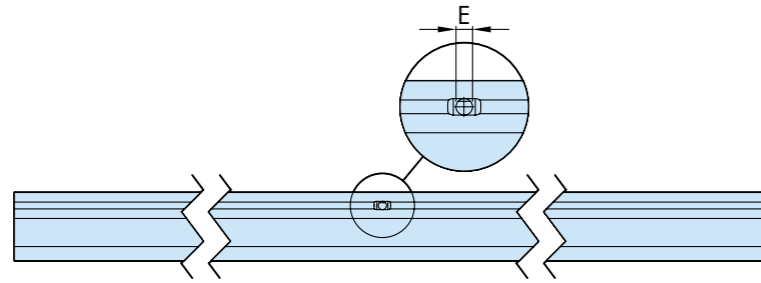
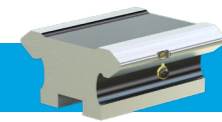

Bleed Lubrication Inserts

The plain bore insert has an O-ring seal between the mounting base and the Slide to stop lubricant escaping. The threaded version has an M5 male stud fitting through which the lubricant is pumped. Please refer to the diagrams below. For more information please contact Hepco's technical department.

Threaded Insert (BLT)

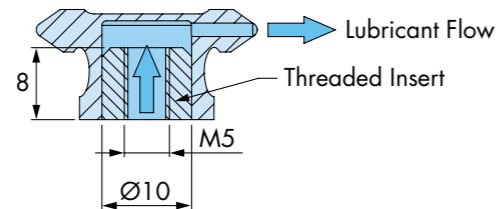

Plain Bore Insert (BLP)

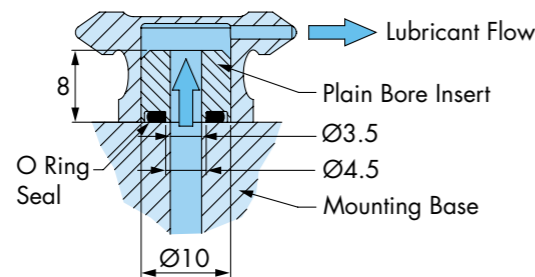

Male Stud Connectors

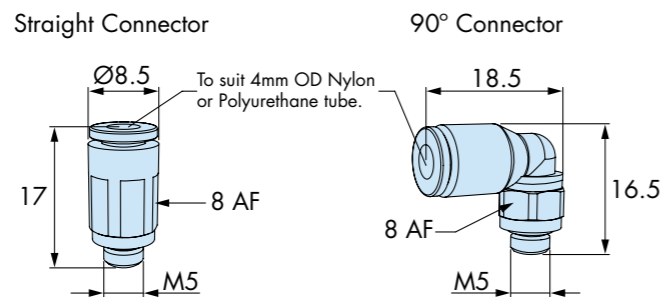

The tube used with the standard male stud fitting is 4mm diameter nylon or polyurethane tube. Alternative sizes of male stud fittings and tube are available on request. Please contact Hepco's technical department for more information.

Slide Part Number	For Use With	A*1,2	B*1,2	C	D*3	ØE	K
NMS12		Bleed lubrication unavailable					
NV20		435	375	8	M5 / Ø3.5	1.5	-
NV28		435	375	8	M5 / Ø3.5	1.5	-
NS25		435	375	10	M5 / Ø3.5	1.5	-
NS35		435	375	10	M5 / Ø3.5	1.5	6.25
NS50		435	375	10	M5 / Ø3.5	1.5	12
NM44		435	375	12.5	M5 / Ø3.5	1.5	6.25
NM60		435	375	12.5	M5 / Ø3.5	2.0	13
NM76		435	375	12.5	M5 / Ø3.5	2.0	17.5
NL76		330	210	19.5	M5 / Ø3.5	2.0	18
NL120		330	210	19.5	M5 / Ø3.5	2.0	38
NMSE			Bleed lubrication unavailable				
NVE							
NSE	375*4		-	10	M5 / Ø3.5	1.5	-
NME	375*4		-	12.5	M5 / Ø3.5	2.0	-
NLE	390*4		-	19.5	M5 / Ø3.5	2.0	22.25

Auto Lubrication Canister

This can be set to dispense the lubricant to the Slide at regular intervals and can be adjusted, depending on the application. Please specify at the time of ordering, if required.

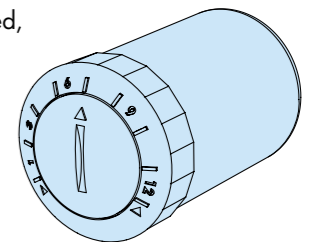

Ordering Details

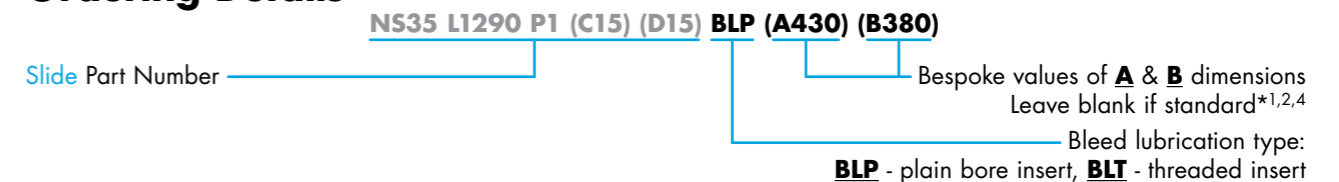

Ordering Example:

- 1 x NME L2336 P2 BLP A400 — Single Edge Spacer Slide, 2336mm long, P2 grade, with custom hole position A
- 1 x NME L2336 P2 BLP A1850 — Single Edge Spacer Slide, 2336mm long, P2 grade, with custom hole position A

Male Stud Connectors are available on request. Please use the ordering details below if required.

For Straight Male Stud Connectors use **31010419**

For 90° Male Stud Connectors use **31990419**

Notes:

- Dimensions A and B are distances from the centre of the mounting hole positioned nearest to the right-hand end of the Slide.
- Custom position bleed holes can be specified, but cannot be located more than 600mm from the end of the Slide. Mounting holes should be avoided.
- Depends on whether a plain or threaded insert is used.
- To order a symmetrical pair of Single Edge Spacer Slides with Bleed Lubrication, one of the Slides should be an opposite handed version, with an adjusted bleed hole position dimension A to reflect this. This is shown in the ordering example above.



Hepco's Side Access Adjustment offers an alternate method of Bearing adjustment, available as an option for size Ø25, Ø34 and Ø54 standard Bearings. It is advantageous in applications where access required to adjust standard eccentric or double eccentric Bearings is limited.

SAA also provides sufficient Bearing displacement to enable a Carriage to be removed from a system without the need to disassemble or run the Carriage off the end of the Slide.

Adjustment is made via two hexagon screws located in the side of the Carriage plate. Any fixings or customer mounted mechanisms need not be removed from the Carriage.

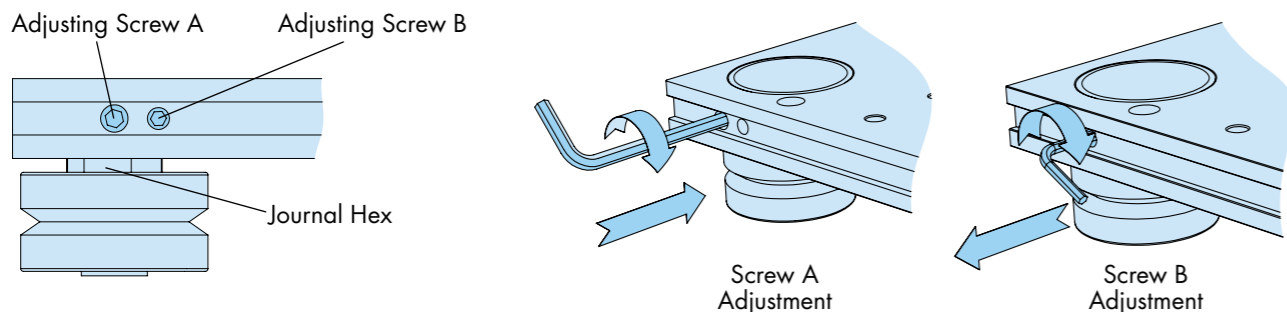

Carriage Plate Part Number	Bearing Ø	Journal Hex A/F (mm)	Hex Key A/F (mm)		Travel (mm)
			Screw A	Screw B	
AU 25 25 ... SAA	25	19	3	2	4
AU 35 25 ... SAA					
AU 50 25 ... SAA					
AU 44 34 ... SAA	34	25	3	2.5	4.5
AU 60 34 ... SAA					
AU 76 34 ... SAA					
AU 76 54 ... SAA	54	37	4	3	6.5
AU 120 54 ... SAA					

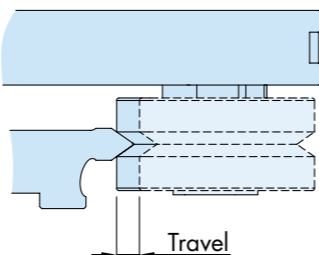

Setting Procedure

Step 1

Using hex keys (as per the table above), check that Screws A and B are disengaged (but not removed). Rotate the journal hex to ensure that the Bearing is loose, and then re-tighten to approximately 50% of the tightening torque specified on 3, to remove any play between the Bearing and Carriage plate.

Step 2

Adjust the Bearing towards the Slide, by rotating Screw A clockwise, until the desired pre-load is achieved. Pre-load can be repeatedly checked by rotating the Bearing between the forefinger and thumb whilst keeping the Carriage stationary on the Slide, so that the Bearing skids against the Slide Vee. A degree of resistance should be felt but the Bearing should rotate without difficulty.

If the level of pre-load needs to be reduced, loosen Screw A by rotating it anticlockwise, then move the Bearing away from the Slide by rotating Screw B clockwise. Repeat Step 2 until the desired pre-load is achieved.

Step 3

Tighten Adjusting Screw B (by rotating the screw clockwise) to lock the position of the Bearing. When both SAA type Bearings on the Carriage have been adjusted and set, fully tighten the journal hexes to the recommended torque settings on 3.

Ordering Details*1

AU4434 L180 (LB) (DR) (NS) (CHK) SAA + Slide Part Number

Carriage plate type ——— **SAA** = Side Access Adjustment option
LB = Bearing Lubricators ——— Bearing options
 Leave blank if not required.

Ordering Example: 2 x (3 x AU6034 L200 LB DR SAA + NM60 L3056 P1) (2 systems each with 3 Carriages per Slide)

Notes:
 1. Cap Seals and Slide Lubricators are incompatible with Side Access Adjustment. Bearing Lubricators must be used where system lubrication is required.

BLANK PAGE

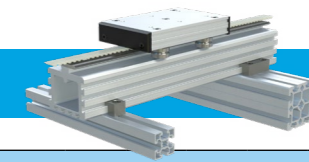

There are five basic types of junction when attaching GV3 Slide Beams to a framework system. These are shown in the illustrations below.

There are three basic types of Fixing Bracket, in several sizes, available for connecting Slide Beam units to a framework system. Hepco Fixing Brackets are also suitable for attaching Slide Beam units to corresponding sizes of profile supplied by most other framework system manufacturers. Simply check that the T-slot opening and T-slot centres correspond with Hepco MCS and use the manufacturers T nuts with required thread size. The screw length may need adjusting.

To determine the possible combinations of Fixing Bracket and Slide Beam units for the required junctions, refer to the table opposite. For detailed information on relevant Hepco products, please contact Hepco.

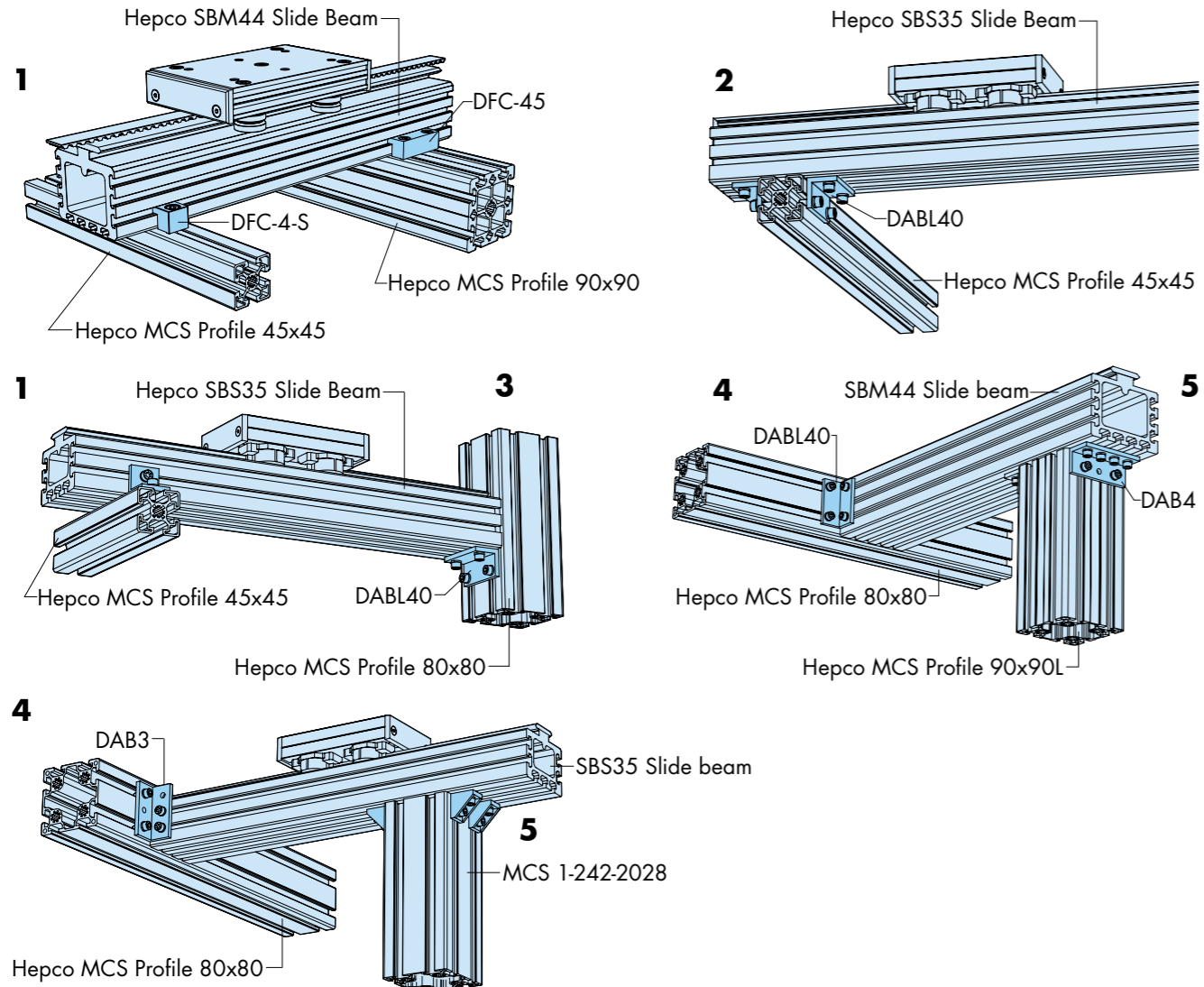

Fixing Brackets

For more information and dimensions on brackets, please refer to Hepco [DLS](#) and [MCS](#) catalogues. All brackets have holes and slots with clearance for M6 screws, unless otherwise stated. (Screws specified but not supplied: refer to table.)

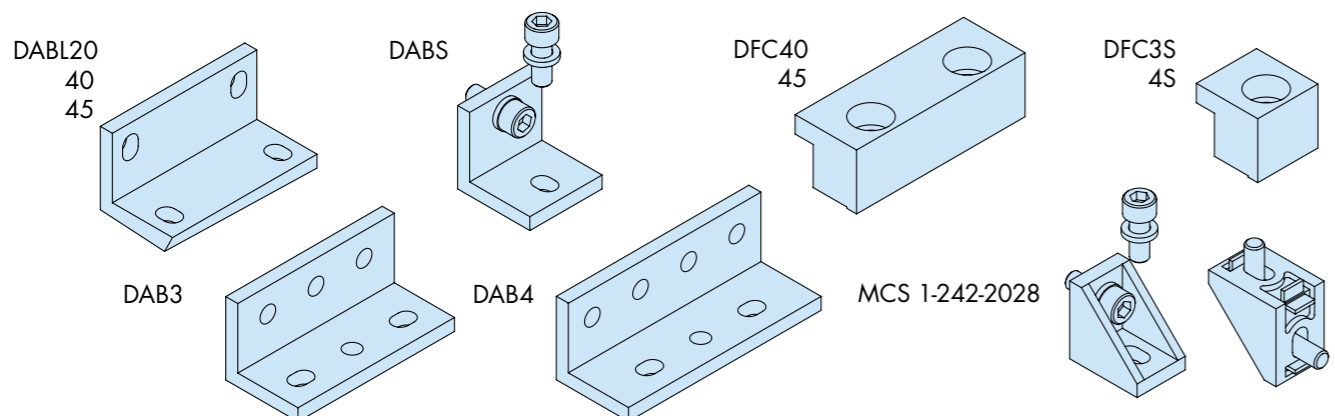

Joint	Slide Beam Type	Bracket	Part Number (or Screw Size)		MCS Profile																	
			Attaching bracket to MCS Profiles		Attaching bracket to Slide Beam																	
			T-Nut	Screw	T-Nut	Screw	30x30	30x60	30x90	40x40	40x80	45x45	45x60	45x90	60x60	80x80	90x90	80x160				
1	SBS & SBM	DFC-3-S	1-242-1026	M6x22	NONE	NONE	✓	✓	✓													
			1-242-1002	M8x22																		
		DABL-40	1-242-1002	M8x25																		
			1-242-1001	M8x25																		
			1-242-1001	M6x16																		
			1-242-1001	M6x16																		
DAB-S	1-242-1026	M6x12	RTN8M6	M6x16																		
	1-242-1001	M6x16																				
2	SBS & SBM	DABL-40	1-242-1001	M6x16	RTN8M6	M6x16																
			2xDABL20	1-242-1001	M6x16																	
3	SBS	DAB3	1-242-1001	M6x16	RTN8M6	M6x16																
			1-242-1026	M6x12																		
			1-242-2028	M6x12																		
	SBM	DAB4	1-242-1026	M6x12																		
			1-242-1001	M6x16																		
			1-242-2028	M6x12																		
4	SBS	DAB3	1-242-1001	M6x16	RTN8M6	M6x16																
			1-242-1026	M6x12																		
			1-242-1001	M6x12																		
	SBM	DAB3	1-242-1001	M6x16																		
			1-242-1026	M6x12																		
			1-242-1001	M6x12																		
5	SBS	DAB3	1-242-1001	M6x16	RTN8M6	M6x16																
			1-242-1026	M6x12																		
			1-242-2028	M6x12																		
	SBM	DAB4	1-242-1026	M6x12																		
			1-242-1001	M6x16																		
			1-242-1026	M6x12																		

✓ These joints are possible

✓● The joint is possible for only one orientation of the MCS section

✓■ The joint is possible but the bracket is wider than the MCS section

✓◆ Joint is possible but the hollow in the SB is partially exposed.

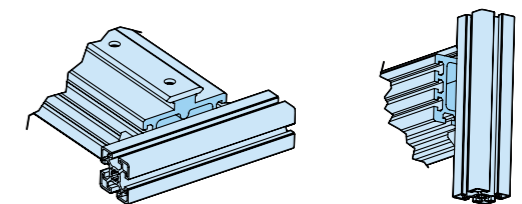
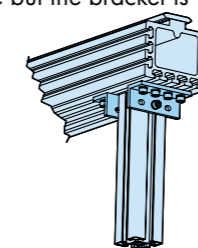

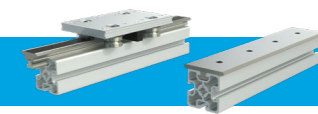

T-Nut Strip provides location of Spacer Slide and retention of fixing screw position in the event of disassembly.

Compatibility Table - GV3 Spacer Slides with MCS Profiles

Width	Height	Slide Part Number			Rack Driven Carriage Availability*2	Belt Drive Carriage Availability*2	
20	20	NV 20					
	20		NV 20 R		*1		
	40	NV 28					
40	20		NV 28 R		*1		
				NVE			
	30	NV 28					
30	30		NV 28 R		*1		
				NVE			
	60	NS 25					
	30		NS 25 R		*1		
	90	NS 35				✓	
	30		NS 35 R		*1		
	60			NSE			
	90	NM 44				✓	
			NM 44 R		✓		
40	40			NME			
		NV 28					
			NV 28 R		*1		
		NS 25					
			NS 25 R		*1		
		NS 35					✓
			NS 35 R		*1		
		NS 50					✓
			NS 50 R		*1		
				NSE			
		NM 44					✓
			NM 44 R		✓		
		NM 60					✓
			NM 60 R		✓		
					NME		
			NLE*4				
160	80	NM 76*3				✓	
			NM 76 R*3		✓		
		NL 76*3,4					
		NL 76 R*3,4		✓			
45	45	NV 28					
			NV 28 R		*1		
		NS 25					
			NS 25 R		*1		
		NS 35					✓
			NS 35 R		*1		
		NS 50					✓
			NS 50 R		*1		
				NSE			
		NM 44					✓
			NM 44 R		✓		
			NM 60				✓
		NM 60 R		✓			
			NME				
			NLE*4				
60	45	NM 76				✓	
			NM 76 R		✓		
		NL 76*4					
60	60						
			NL 76 R*4		✓		

1. Hepco Rack Driven Carriages not available but customers may construct their own using GV3 Pinions.
 2. All types of Carriage with the exception of some sizes of Rack and Belt Driven Carriages are available to suit all sizes of Double Edge Spacer Slides.
 3. NM76 & NL76 Spacer Slides can only be attached to the two centre most positions of the 160mm wide face of the 80 x 160 profile.
 4. Slide hole centres and fixing screw sizes and types will vary from those specified in the GV3 catalogue.

Compatibility Table - GV3 Flat Slides with MCS Profiles

Width	Height	Slide Part No								Belt Driven Carriage Availability*2	
											20
20	40	S 35	✓		✓	✓	✓	✓	✓	✓	
30	30	M 44	✓		✓		P3	✓	✓	✓	
	30				✓	✓	✓	✓	✓	✓	
	60	S 50	✓		✓	✓	✓	✓	✓	✓	
30	90				✓	✓	✓	✓	✓	✓	
60	30	M 76	✓		✓	✓	✓	✓	✓	✓	
90	30	L 120*4	P3		P3	P3	P3	P3	P3		
40	20	S 50	✓		✓		P3	✓	P3	✓	✓
					✓	✓	✓	✓	✓	✓	✓
		M 60	✓		✓	✓	✓	✓	✓	✓	✓
40	80	M 76	✓		✓	✓	✓	✓	✓	✓	
					✓	✓	✓	✓	✓	✓	
		L 76*4	✓		✓	✓	✓	✓	✓	✓	✓
45	45	M 60	✓		✓	✓	✓	✓	✓	✓	
					✓	✓	✓	✓	✓	✓	
		M 76	✓		✓	✓	✓	✓	✓	✓	
45	90	L 76*4	✓		✓	✓	✓	✓	✓	✓	
					✓	✓	✓	✓	✓	✓	
		M 76	✓		✓	✓	✓	✓	✓	✓	
60	45				✓	✓	✓	✓	✓	✓	
					✓	✓	✓	✓	✓	✓	
60	60	L 76*4	P3		P3	P3	P3	P3	P3		
					✓	✓	✓	✓	✓	✓	✓
80	40										
80	80										
80	160										
90	45										
90	90										

✓ = Fits with all grades of Slide P3 = Fits with P3 grade Slide only

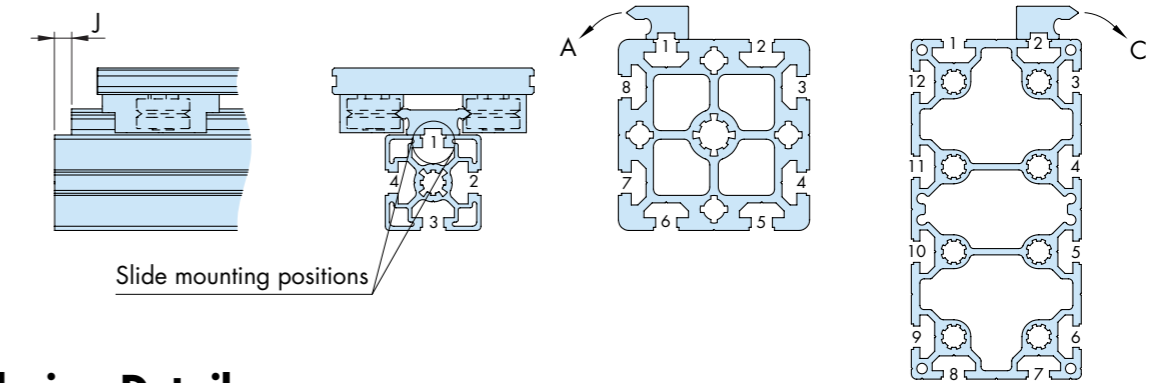

Ordering Details

8080(L) - H2200 - J50 - 2C / NM44 - L806 - P2 - (R) - (C) / 1x AU4434 - L180 - CS - DR

Profile Size **L** Designates alternative shape profile
 Profile Length **H**
 Slide position **J** Leave blank for self assembly
 Slide mounting position number **C** for clockwise or **A** for anti-clockwise facing
 Carriage reference for example only Please specify from GV3 catalogue
C=Counterbored option for flush surface on GV3 Flat Slides
R=Rack mounted to GV3 Spacer Slide GV3 Flat Slide mounting to special order
P2=Slide precision grade Options are P1, P2 & P3
 Slide Length **L**
 Slide part number

CAD

GV3 Catalogue Carriages

GV3 Catalogue Slides

GV3 Catalogue Racks

GV3 Catalogue Pinion

BLANK PAGE

BLANK PAGE

CATALOGUE No. GV3 TECH 03.4 UK © 2022 Hepco Slide Systems Ltd.

Reproduction in whole or part without prior authorisation from Hepco is prohibited. Although every effort has been made to ensure the accuracy of the information in this catalogue, Hepco cannot accept liability for any omissions or errors. Hepco reserves the right to make alterations to the product resulting from technical developments.

Many Hepco products are protected by: Patents, Copyright, Design Right or Registered Design. Infringement is strictly prohibited and may be challenged in law. The Customer's attention is drawn to the following clause in Hepco's conditions of sale:

'It shall be the Customer's sole responsibility to ensure that goods supplied by Hepco will be suitable or fit for any particular application or purpose of the Customer, whether or not such application or purpose is known to Hepco. The Customer will be solely responsible for any errors in, or omissions from, any specifications or information the Customer provides. Hepco will not be obliged to verify whether any such specifications or information are correct or sufficient for any application or purpose.'

Hepco's full conditions of sale are available on request and will apply to all quotations and contracts for the supply of items detailed in this catalogue.

HepcoMotion is the trading name of Hepco Slide Systems Ltd.

HepcoMotion®

ADVANCED LINEAR SOLUTIONS



GV3

Linear Guidance and Transmission System

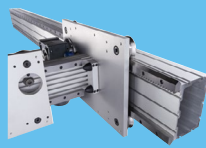

HDS2

Heavy Duty Slide System

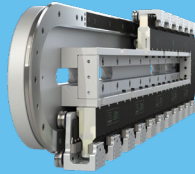

GFX

HepcoMotion Guidance System for Beckhoff XTS

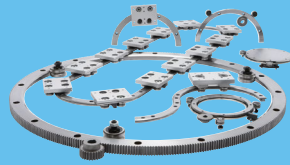

PRT2

Ring Slides and Track System

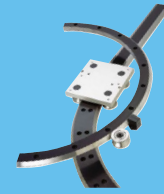

HDRT

Heavy Duty Ring Slides and Track System



SL2

Stainless Steel Based Slide System

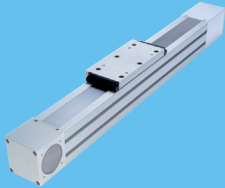

SBD

Sealed Belt Drive

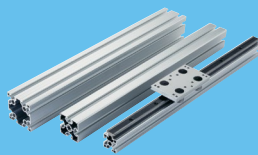

MCS

Aluminium Frame and Machine Construction System

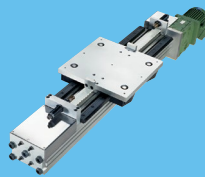

HDLS

Heavy Duty Driven Linear System

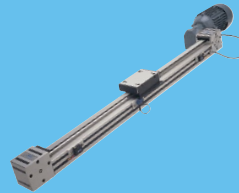

DLS

Linear Transmission and Positioning System

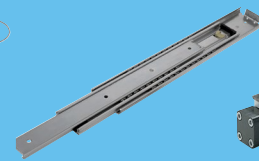

HTS

Telescopic Ball Bearing Slides



HPS

Powerslide-2 Guided Rodless Cylinder

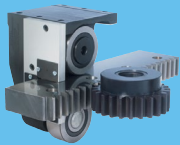

MHD

Heavy Duty Track Roller Guidance System

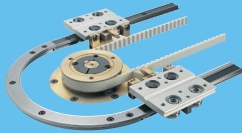

DTS

Driven Track System



Hepco Ball Screws



Simple Select®
Vee Slide Linear Guidance Systems



PDU2

Profile Driven Unit

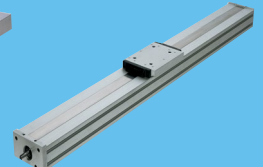

PSD120

Profile Screw Driven Unit

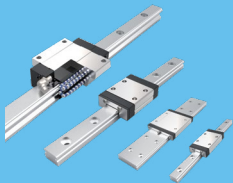

HLG

Hepco Ball Guides

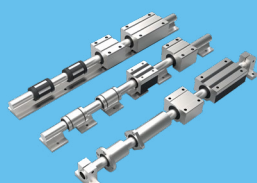

Ball Bushings

Linear Bearing System



Shaft

Precision Steel and Aluminium Shaft



DUAL VEE®

Single Edge Slide System

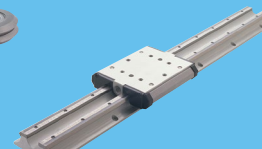

LoPro®

Aluminium Based Slide System

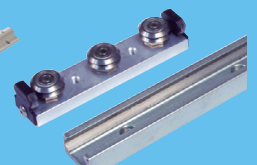

UtiliTrak®

Lightweight U Channel Guideway

For further information on HepcoMotion® products and details of worldwide representation, please visit:

HepcoMotion.com

HepcoMotion Group Headquarters

www.hepcotion.com

Lower Moor Business Park
Tiverton Way, Tiverton
EX16 6TG
England

Tel: +44 (0)1884 257000
Email: sales@hepcotion.com

HepcoMotion Germany

(Also covering Austria & German-speaking Switzerland)

www.hepcotion.com/de

Tel: +49 (0) 9128 92710
Email: info.de@hepcotion.com

HepcoMotion France

(Also covering French-speaking Switzerland)

www.hepcotion.com/fr

Tel: +33 (0) 1 34 64 30 44
Email: info.fr@hepcotion.com

HepcoMotion Benelux

(Covering Belgium, Luxembourg & Netherlands)

www.hepcotion.com/nl

Tel: +31 (0) 492 551290
Email: info.nl@hepcotion.com

HepcoMotion Spain

www.hepcotion.com/es

Tel: +34 93 607 22 55
Email: info.es@hepcotion.com

HepcoMotion South Korea

www.hepcotion.co.kr

Tel: +82 (0) 31 352 7783
Email: hepcokr@chol.com

HepcoMotion China

www.hepcotion.com.cn

Tel: +86 21 5648 9055
Email: sales.china@hepcotion.com



Certification Number 14479
ISO 9001